

SERVICE MANUAL

notebook

**NH55HHQ / NH55HJQ / NH55HKQ /
NH58HHQ / NH58HJQ / NH58HKQ**



Notebook Computer

**NH55HHQ / NH55HJQ / NH55HKQ / NH58HHQ / NH58HJQ /
NH58HKQ**

Service Manual

Notice

The company reserves the right to revise this publication or to change its contents without notice. Information contained herein is for reference only and does not constitute a commitment on the part of the manufacturer or any subsequent vendor. They assume no responsibility or liability for any errors or inaccuracies that may appear in this publication nor are they in anyway responsible for any loss or damage resulting from the use (or misuse) of this publication.

This publication and any accompanying software may not, in whole or in part, be reproduced, translated, transmitted or reduced to any machine readable form without prior consent from the vendor, manufacturer or creators of this publication, except for copies kept by the user for backup purposes.

Brand and product names mentioned in this publication may or may not be copyrights and/or registered trademarks of their respective companies. They are mentioned for identification purposes only and are not intended as an endorsement of that product or its manufacturer.

Version 1.0
May 2021

Trademarks

Intel and Intel Core are trademarks of Intel Corporation.

Windows[®] is a registered trademark of Microsoft Corporation.

Other brand and product names are trademarks and /or registered trademarks of their respective companies.

HDMI™
HIGH-DEFINITION MULTIMEDIA INTERFACE

About this Manual

This manual is intended for service personnel who have completed sufficient training to undertake the maintenance and inspection of personal computers.

It is organized to allow you to look up basic information for servicing and/or upgrading components of the *NH55HHQ* / *NH55HJQ* / *NH55HKQ* / *NH58HHQ* / *NH58HJQ* / *NH58HKQ* series notebook PC.

The following information is included:

Chapter 1, Introduction, provides general information about the location of system elements and their specifications.

Chapter 2, Disassembly, provides step-by-step instructions for disassembling parts and subsystems and how to upgrade elements of the system.

Appendix A, Part Lists

Appendix B, Schematic Diagrams

IMPORTANT SAFETY INSTRUCTIONS

Follow basic safety precautions, including those listed below, to reduce the risk of fire, electric shock and injury to persons when using any electrical equipment:

1. Do not use this product near water, for example near a bath tub, wash bowl, kitchen sink or laundry tub, in a wet basement or near a swimming pool.
2. Avoid using a telephone (other than a cordless type) during an electrical storm. There may be a remote risk of electrical shock from lightning.
3. Do not use the telephone to report a gas leak in the vicinity of the leak.
4. Use only the power cord and batteries indicated in this manual. Do not dispose of batteries in a fire. They may explode. Check with local codes for possible special disposal instructions.
5. This product is intended to be supplied by a Listed Power Unit as follows:
 - AC Input of 100 - 240V, 50 - 60Hz, DC Output of 19.5V, 6.15A (**120** Watts) or 19.5V, 7.7A (**150** Watts) minimum AC/DC Adapter.

FCC Statement

This device complies with Part 15 of the FCC Rules. Operation is subject to the following two conditions:

This device may not cause harmful interference.

This device must accept any interference received, including interference that may cause undesired operation.

Instructions for Care and Operation

The notebook computer is quite rugged, but it can be damaged. To prevent this, follow these suggestions:

1. **Don't drop it, or expose it to shock.** If the computer falls, the case and the components could be damaged.

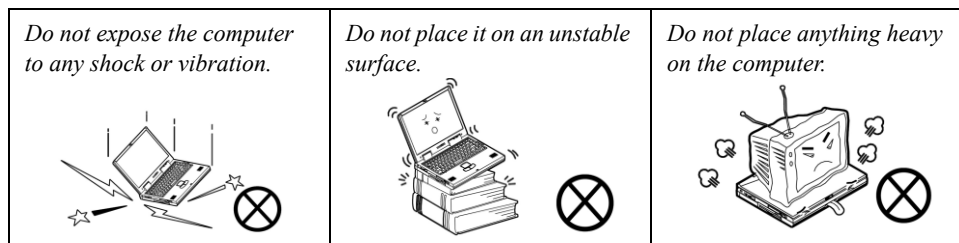

2. **Keep it dry, and don't overheat it.** Keep the computer and power supply away from any kind of heating element. This is an electrical appliance. If water or any other liquid gets into it, the computer could be badly damaged.

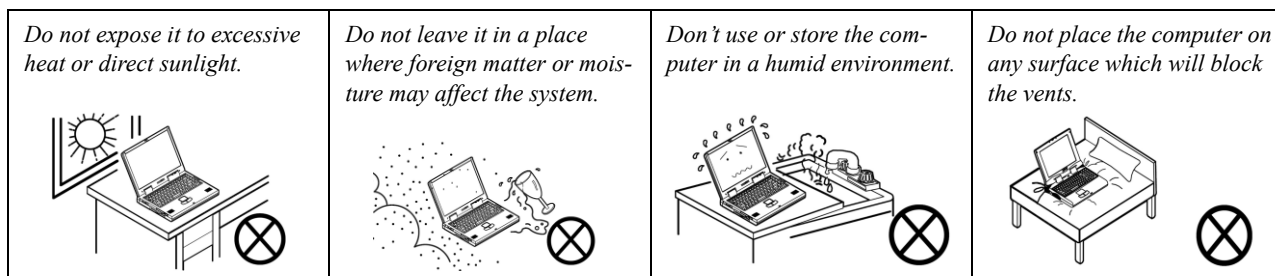

3. **Follow the proper working procedures for the computer.** Shut the computer down properly and don't forget to save your work. Remember to periodically save your data as data may be lost if the battery is depleted.

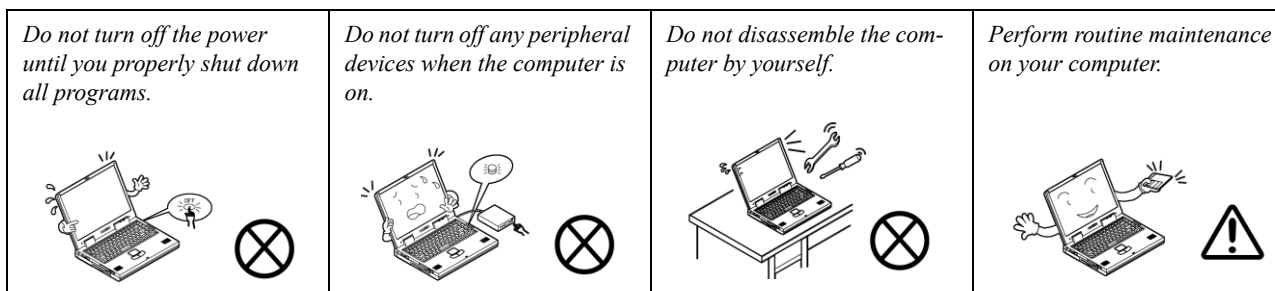

4. **Avoid interference.** Keep the computer away from high capacity transformers, electric motors, and other strong magnetic fields. These can hinder proper performance and damage your data.
5. **Take care when using peripheral devices.**

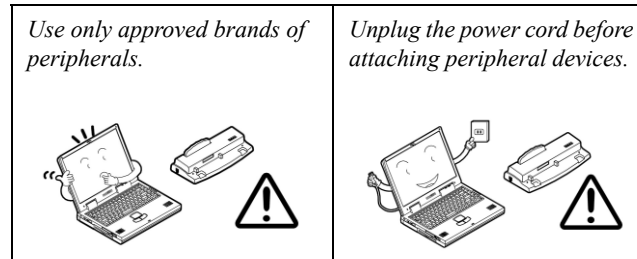

Power Safety

The computer has specific power requirements:

- Only use a power adapter approved for use with this computer.
- Your AC adapter may be designed for international travel but it still requires a steady, uninterrupted power supply. If you are unsure of your local power specifications, consult your service representative or local power company.
- The power adapter may have either a 2-prong or a 3-prong grounded plug. The third prong is an important safety feature; do not defeat its purpose. If you do not have access to a compatible outlet, have a qualified electrician install one.
- When you want to unplug the power cord, be sure to disconnect it by the plug head, not by its wire.
- Make sure the socket and any extension cord(s) you use can support the total current load of all the connected devices.
- Before cleaning the computer, make sure it is disconnected from any external power supplies.

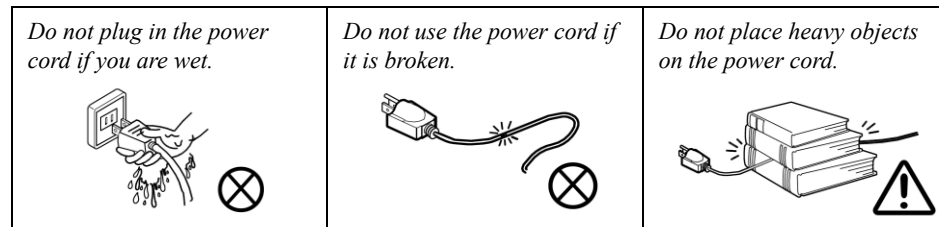

Power Safety Warning

Before you undertake any upgrade procedures, make sure that you have turned off the power, and disconnected all peripherals and cables (including telephone lines and power cord). It is advisable to also remove your battery in order to prevent accidentally turning the machine on.

Battery Precautions

- Only use batteries designed for this computer. The wrong battery type may explode, leak or damage the computer.
- Do not continue to use a battery that has been dropped, or that appears damaged (e.g. bent or twisted) in any way. Even if the computer continues to work with a damaged battery in place, it may cause circuit damage, which may possibly result in fire.
- Recharge the batteries using the notebook's system. Incorrect recharging may make the battery explode.
- Do not try to repair a battery pack. Refer any battery pack repair or replacement to your service representative or qualified service personnel.
- Keep children away from, and promptly dispose of a damaged battery. Always dispose of batteries carefully. Batteries may explode or leak if exposed to fire, or improperly handled or discarded.
- Keep the battery away from metal appliances.
- Affix tape to the battery contacts before disposing of the battery.
- Do not touch the battery contacts with your hands or metal objects.

Battery Guidelines

The following can also apply to any backup batteries you may have.

- If you do not use the battery for an extended period, then remove the battery from the computer for storage.
- Before removing the battery for storage charge it to 60% - 70%.
- Check stored batteries at least every 3 months and charge them to 60% - 70%.



Battery Disposal

The product that you have purchased contains a rechargeable battery. The battery is recyclable. At the end of its useful life, under various state and local laws, it may be illegal to dispose of this battery into the municipal waste stream. Check with your local solid waste officials for details in your area for recycling options or proper disposal.

Caution

Danger of explosion if battery is incorrectly replaced. Replace only with the same or equivalent type recommended by the manufacturer. Discard used battery according to the manufacturer's instructions.

Battery Level

Click the battery icon  in the taskbar to see the current battery level and charge status. A battery that drops below a level of 10% will not allow the computer to boot up. Make sure that any battery that drops below 10% is recharged within one week.

Related Documents

You may also need to consult the following manual for additional information:

User's Manual on CD/DVD

This describes the notebook PC's features and the procedures for operating the computer and its ROM-based setup program. It also describes the installation and operation of the utility programs provided with the notebook PC.

System Startup

1. Remove all packing materials.
2. Place the computer on a stable surface.
3. Insert the battery and make sure it is locked in position.
4. Securely attach any peripherals you want to use with the computer (e.g. keyboard and mouse) to their ports.
5. **When first setting up the computer use the following procedure** (as to safeguard the computer during shipping, the battery will be locked to not power the system until first connected to the AC/DC adapter and initially set up as below):
 - Attach the AC/DC adapter cord to the DC-In jack on the rear of the computer, then plug the AC power cord into an outlet, and connect the AC power cord to the AC/DC adapter. The battery will now be unlocked.
6. Use one hand to raise the lid/LCD to a comfortable viewing angle (do not exceed 130 degrees); use the other hand (as illustrated in Figure 1) to support the base of the computer (**Note: Never** lift the computer by the lid/LCD).
7. Press the power button to turn the computer "on".

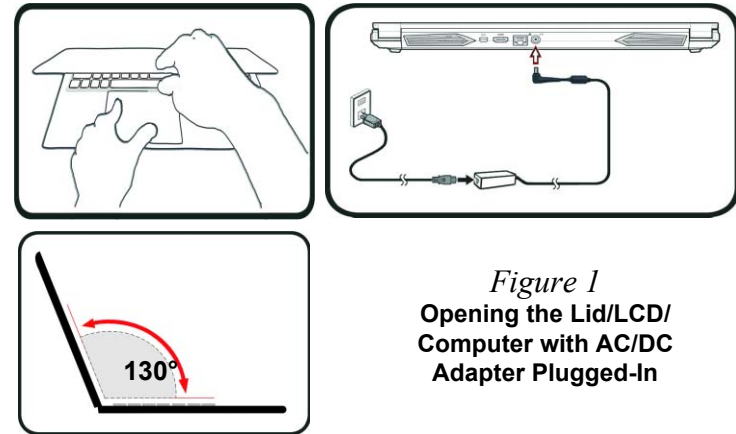



Figure 1
**Opening the Lid/LCD/
Computer with AC/DC
Adapter Plugged-In**

Shut Down

Note that you should always shut your computer down by choosing the **Shut down** command in **Windows** (see below). This will help prevent hard disk or system problems.

Click the icon  in the **Start Screen** and choose **Shut down** from the menu.



Or

Right-click the **Start button**  at the bottom of the **Start Screen** or the **Desktop** and choose **Shut down or sign out** > **Shut down** from the context menu.

Contents

Introduction1-1

Overview	1-1
Specifications	1-2
External Locator - Top View with LCD Panel Open	1-4
External Locator - Front & Right Side Views	1-5
External Locator - Left Side & Rear View	1-6
External Locator - Bottom View	1-7
Mainboard Overview - Top (Key Parts)	1-8
Mainboard Overview - Bottom (Key Parts)	1-9
Mainboard Overview - Top (Connectors)	1-10
Mainboard Overview - Bottom (Connectors)	1-11

Disassembly2-1

Overview	2-1
Maintenance Tools	2-2
Connections	2-2
Maintenance Precautions	2-3
Disassembly Steps	2-4
Removing the Battery	2-5
Removing the Keyboard	2-6
Removing the Hard Disk Drive	2-7
Removing the System Memory (RAM)	2-9
Removing the M.2 SSD Module	2-10
Removing the Wireless LAN Module	2-11
Wireless LAN, Combo Module Cables	2-12
Removing the CCD	2-13

Part ListsA-1

Part List Illustration Location	A-2
Top	A-3
Bottom	A-4

Main Board	A-5
HDD	A-6
LCD (NH55HHQ/NH55HJQ/NH55HKQ)	A-7
LCD (NH58HHQ/NH58HJQ/NH58HKQ)	A-8

Schematic Diagrams.....B-1

System Block Diagram	B-2
Processor 1/8	B-3
Processor 2/8	B-4
Processor 3/8	B-5
Processor 4/8	B-6
Processor 5/8	B-7
Processor 6/8	B-8
Processor 7/8	B-9
Processor 8/8	B-10
PCH 1/8	B-11
PCH 2/8	B-12
PCH 3/8	B-13
PCH 4/8	B-14
PCH 5/8	B-15
PCH 6/8	B-16
PCH 7/8	B-17
PCH 8/8	B-18
DDR4 SO_DIMM_0	B-19
DDR4 SO_DIMM_1	B-20
VGA PCI Express	B-21
GPU Frame Buffer A/B	B-22
Frame Buffer A	B-23
Frame Buffer A	B-24
Frame Buffer B	B-25
Frame Buffer B	B-26

Preface

VGA NVVDD Coupling	B-27	NVVDD2	B-59
Straps and XTAL	B-28	PEX_VDD	B-60
IFP I/O Interface	B-29	FBVDDQ	B-61
Misc - GPIO, I2C and ROM	B-30	OVRM	B-62
NVIDIA Power Sequence	B-31	Click Board	B-63
GPU NVVDD, FBVDDQ	B-32	LED Board	B-64
GPU GND	B-33	Audio Board	B-65
Panel	B-34	Audio Board + Redriver	B-66
mDP	B-35	NH77 PW Board	B-67
HDMI	B-36	NH50 PW Board	B-68
Audio Codec	B-37	NH55 PW Board	B-69
Card Reader & LAN_RTL5227S	B-38	Power Sequence	B-70
LAN RTL8111H RTD3	B-39	Power Map	B-71
USB Type-A	B-40		
USB Type-C	B-41		
M.2 PCIE 4X/SATA SSD	B-42		
M.2 WLAN+BT, PCIE 4X SSD	B-43		
HDD, Click TP, Audio	B-44		
LED, CCD, Power SW Bd.	B-45		
KBC-ITE IT5570	B-46		
RGB KB, Fan	B-47		
VDD3, VDD5	B-48		
1V8_RUN/AON, NV3V3, 3.3VS	B-49		
3V, 5V, 3VS, 5VS	B-50		
VCCST, VCCSTG, 1.8VS	B-51		
VNN / V1.05	B-52		
VCCIN	B-53		
VCCIN Output	B-54		
AC_In, Charger	B-55		
VCCIN AUX	B-56		
DDR 1.2V / 0.6VS, 2.5V	B-57		
NVVDD1	B-58		

Chapter 1: Introduction

Overview

This manual covers the information you need to service or upgrade the *NH55HHQ* / *NH55HJQ* / *NH55HKQ* / *NH58HHQ* / *NH58HJQ* / *NH58HKQ* series notebook computer. Information about operating the computer (e.g. getting started, and the *Setup* utility) is in the *User's Manual*. Information about drivers (e.g. VGA & audio) is also found in the *User's Manual*. The manual is shipped with the computer.

Operating systems (e.g. *Windows 10*, etc.) have their own manuals as do application softwares (e.g. word processing and database programs). If you have questions about those programs, you should consult those manuals.

The *NH55HHQ* / *NH55HJQ* / *NH55HKQ* / *NH58HHQ* / *NH58HJQ* / *NH58HKQ* series notebook is designed to be upgradeable. See *Disassembly on page 2 - 1* for a detailed description of the upgrade procedures for each specific component. Please take note of the warning and safety information indicated by the “” symbol.

The balance of this chapter reviews the computer's technical specifications and features.

Introduction

Specifications



Latest Specification Information

The specifications listed here are correct at the time of sending them to the press. Certain items (particularly processor types/speeds) may be changed, delayed or updated due to the manufacturer's release schedule. Check with your service center for more details.



CPU

The CPU is not a user serviceable part. Accessing the CPU in any way may violate your warranty.

Processor Options

Intel® Core™ i7 Processor

i7-11800H (2.30GHz)

16B Smart Cache, 14nm, TDP 45W

i7-11600H (2.90GHz)

12MB Smart Cache, 14nm, TDP 45W

i7-11400H (2.70GHz)

16B Smart Cache, 14nm, TDP 45W

i7-11260H (2.60GHz)

12MB Smart Cache, 14nm, TDP 45W

Core Logic

Intel® HM570 Express Chipset

BIOS

128Mb SPI Flash ROM

INSYDE BIOS

Memory

Dual Channel DDR4

Two 260 Pin SO-DIMM Sockets

Supporting up to **3200MHz DDR4** Memory

Memory Expandable up to **64GB**

Compatible with 8GB, 16GB or 32GB Modules

(The real memory operating frequency depends on the FSB of the processor.)

Storage

One changeable 2.5" (6cm) **7.0mm (h) SATA** (Serial) Hard Disk Drive/Solid State Drive (SSD)

Two M.2 SSDs:

One M.2 PCIe **Gen4 x4** Solid State Drive (SSD)*

One M.2 **SATA/PCIe Gen3 x4** Solid State Drive (SSD)*

*Supporting RAID Level 0/1 with two PCIe SSDs (**PCIe Gen3 x4**)

Audio

High Definition Audio Compliant Interface

Sound Blaster™ Cinema 6

Built-In Array Microphone

Two Speakers

LCD Options

15.6" (39.62cm), 16:9, FHD (1920x1080)

Video Adapter

Intel® Integrated GPU and NVIDIA® Discrete GPU

Supports Microsoft Hybrid Graphics

Intel Integrated GPU

Intel® UHD Graphics

Dynamic Frequency

Intel Dynamic Video Memory Technology

Microsoft DirectX®12 Compatible

NVIDIA® Discrete GPU

NVIDIA® GeForce RTX 3050 (GN20-P1) - NH5xHJQ

4GB GDDR6 Video RAM on board

Microsoft DirectX® 12 Compatible

NVIDIA® GeForce RTX 3050 Ti (GN20-P1) - NH5xHKQ

4GB GDDR6 Video RAM on board

Microsoft DirectX® 12 Compatible

NVIDIA® GeForce GTX 1650 (N18P-G61-A) - NH5xHHQ

4GB GDDR6 Video RAM on board

Microsoft DirectX® 12 Compatible

Security

Security (Kensington® Type) Lock Slot

BIOS Password

FTPM for Systems Without TPM Hardware

(**Factory Option**) TPM 2.0

Keyboard

Full-size **Multi-Color** LED Keyboard (with Numeric Keypad)

Pointing Device

Built-In Touchpad (with Microsoft PTP Multi Gesture & Scrolling Functionality)

Card Reader

Embedded Multi-In-1 Push-Push Card Reader
 MMC (MultiMedia Card)/RS MMC
 SD (Secure Digital)/Mini SD/SDHC/ SDXC

M.2 Slots

Slot WLAN for **Combo WLAN and Bluetooth** Module
 Slot SSD1 for **PCIe Gen4 x4 SSD**
 Slot SSD2 for **SATA** or **PCIe Gen3 x4 SSD**

Interface

One USB 2.0 Port
 One USB 3.2 Gen 1 Type-A Port
 One USB 3.2 Gen 2 Type-A Port
 One USB 3.2 Gen 2 Type-C Port*
**The maximum amount of current supplied by USB Type-C ports is 500mA (USB 2.0)/900mA (USB3.2).*
 One Mini DisplayPort 1.4
 One HDMI-Out Port
 One Microphone-In Jack
 One 2- In-1 Audio Jack (Headphone / Microphone)
 One RJ-45 LAN Jack
 One DC-In Jack

Communication

Built-In 10/100/1000Mb Base-TX Ethernet LAN
 1.0M HD Webcam

WLAN/ Bluetooth M.2 Modules:

(Factory Option) Intel® Dual Band Wi-Fi 6 AX200, 2x2 AX Wireless LAN + Bluetooth

(Factory Option) Intel® Dual Band Wi-Fi 6 AX201, 2x2 AX Wireless LAN + Bluetooth

(Factory Option) Intel® Dual Band Wi-Fi 5 Wireless-AC 9462, 1x1 AC Wireless LAN + Bluetooth

Environmental Spec**Temperature**

Operating: 5°C - 35°C
 Non-Operating: -20°C - 60°C

Relative Humidity

Operating: 20% - 80%
 Non-Operating: 10% - 90%

Power

Removable 4 Cell Smart Lithium-Ion Battery Pack, 41WH
(Factory Option) Removable 4 Cell Smart Lithium-Ion Battery Pack, 48.96WH

Full Range AC/DC Adapter

AC Input: 100 - 240V, 50 - 60Hz
 DC Output: 19.5V, 6.15A (**120W**) - NH5xHHQ

Or

DC Output: 19.5V, 7.7A (**150W**) - NH5xHJQ, NH5xHKQ

Dimensions & Weight

361mm (w) * 258mm (d) * 27.9mm (h)
2.2kg (Barebone with 48.96WH Battery)

Introduction

External Locator - Top View with LCD Panel Open

Figure 1
Top View

1. Webcam
2. *Camera LED
**When the PC camera is in use, the LED will be illuminated.*
3. Built-In Array Microphone
4. Display
5. Power Button
6. Keyboard
7. Touchpad & Buttons

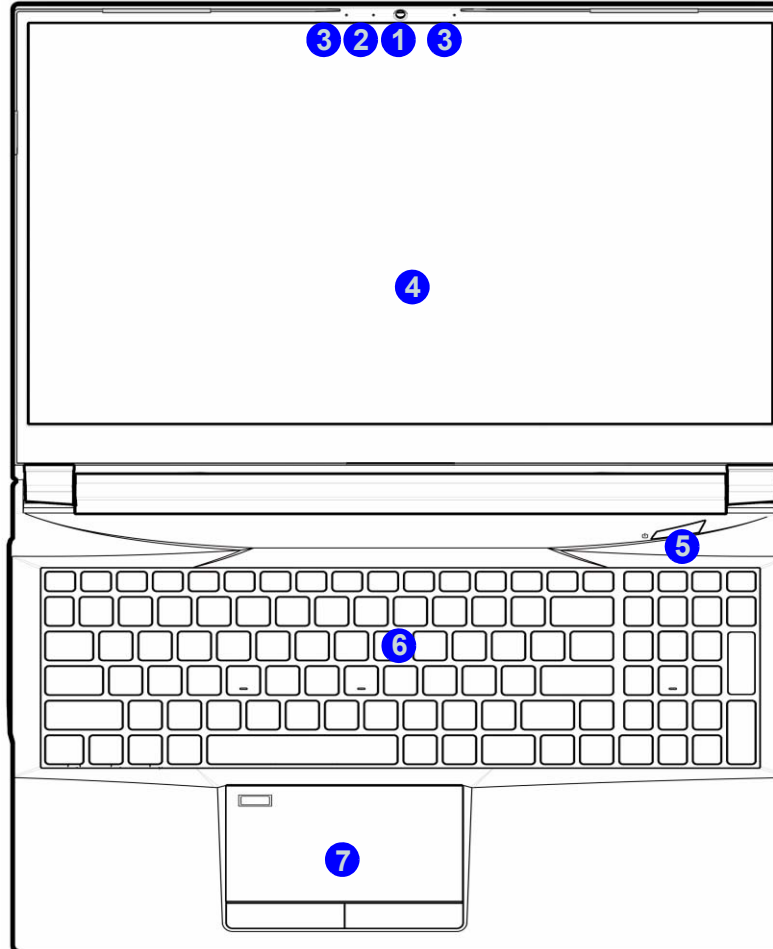

External Locator - Front & Right Side Views

Figure 2
Front View

1. LED Indicators

FRONT VIEW



RIGHT SIDE VIEW

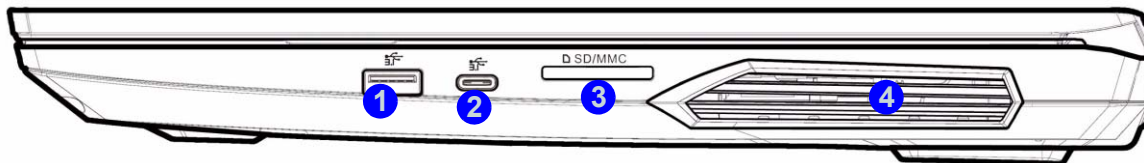

Figure 3
Right Side View

1. USB 3.2 Gen 2 Type-A Port
2. USB 3.2 Gen 2 Type-C Port
3. Multi-in-1 Card Reader
4. Vent

Introduction

External Locator - Left Side & Rear View

Figure 4

Left Side View

1. Security Lock Slot
2. Vent
3. USB 3.2 Gen 1 Type-A Port
4. USB 2.0 Port
5. Microphone-In Jack
6. 2-In-1 Audio Jack (Headphone and Microphone)

LEFT SIDE VIEW

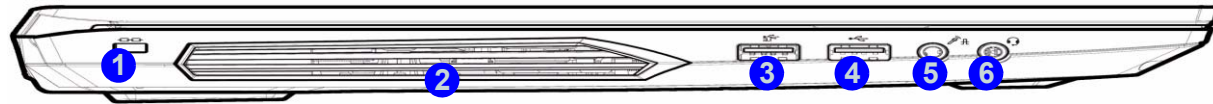

REAR VIEW

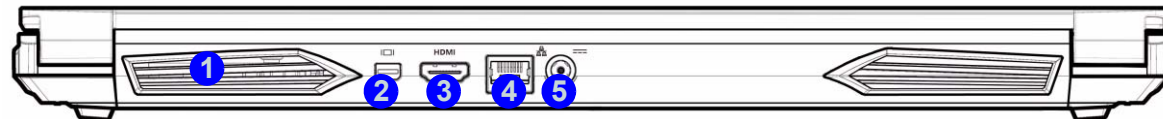

Figure 5

Rear View

1. Vent
2. Mini DisplayPort 1.4
3. HDMI-Out Port
4. RJ-45 LAN Jack
5. DC-In Jack

External Locator - Bottom View

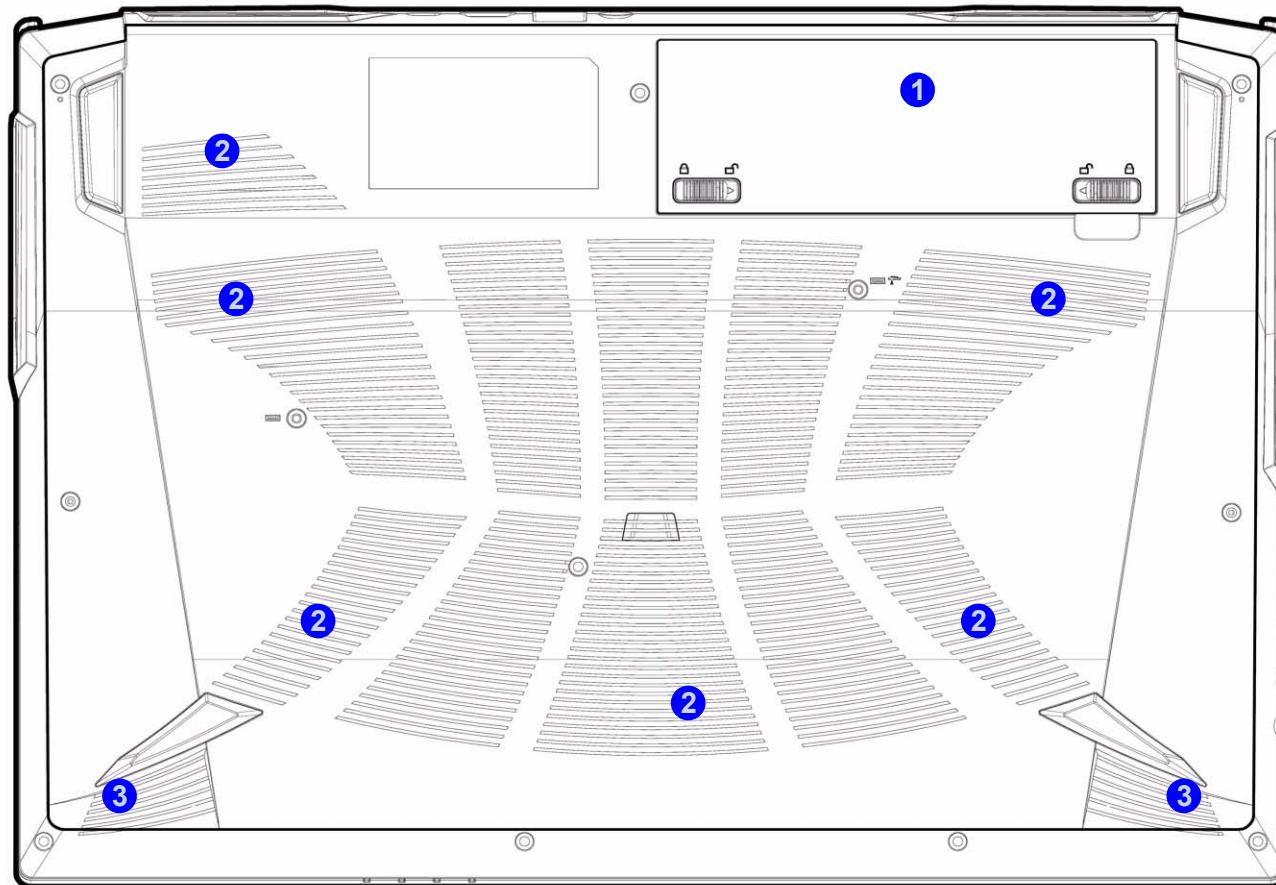

Figure 6
Bottom View

1. Battery
2. Vent
3. Speakers



Overheating

To prevent your computer from overheating, make sure nothing blocks any vent while the computer is in use.

Introduction

Figure 7
Mainboard Top
Key Parts

1. KBC-ITE IT5570

Mainboard Overview - Top (Key Parts)

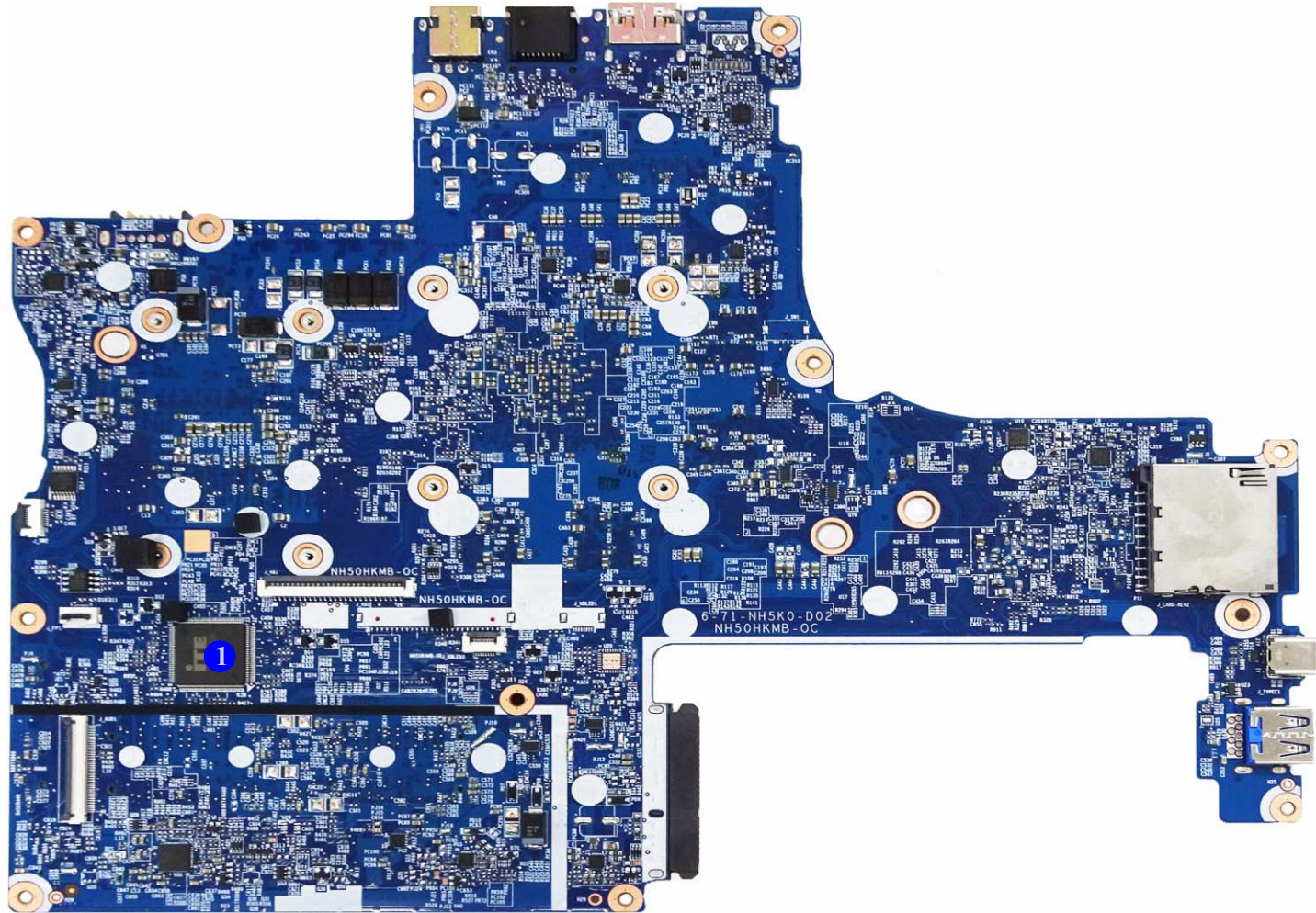

Mainboard Overview - Bottom (Key Parts)

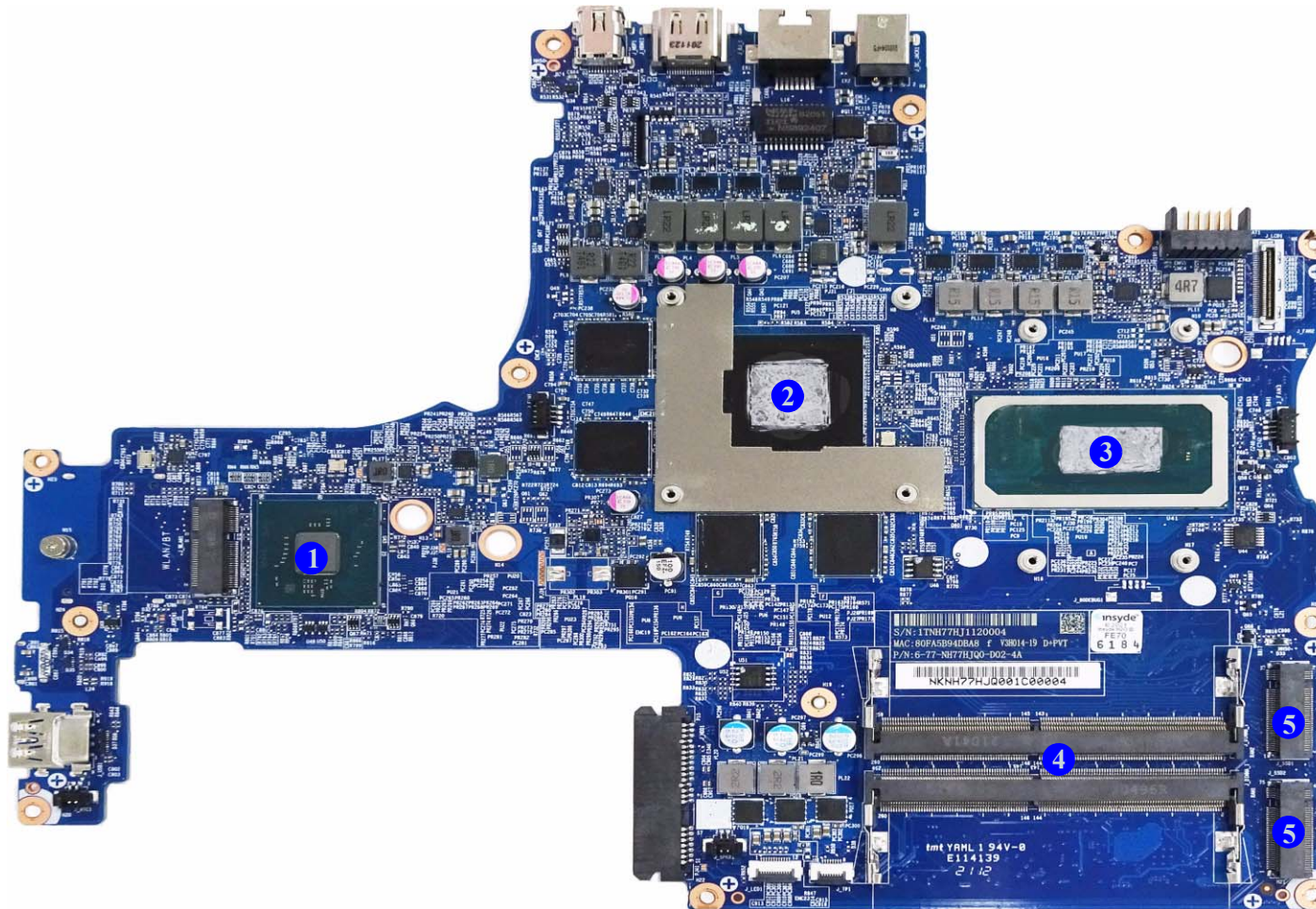

Figure 8
Mainboard Bottom
Key Parts

1. Mini-Card Connector (WLAN Module)
2. GPU
3. CPU
4. Memory Slots (DDR4 SO-DIMM)
5. M.2 Card Connector (SATA/PCIE SSD)

Mainboard Overview - Top (Connectors)

Figure 9
**Mainboard Top
Connectors**

1. USB Connector
2. Keyboard Cable Connector
3. KB LED Connector
4. USB 3.2 Gen 2 Type-C Port
5. USB 3.2 Gen 2 Type-A Port

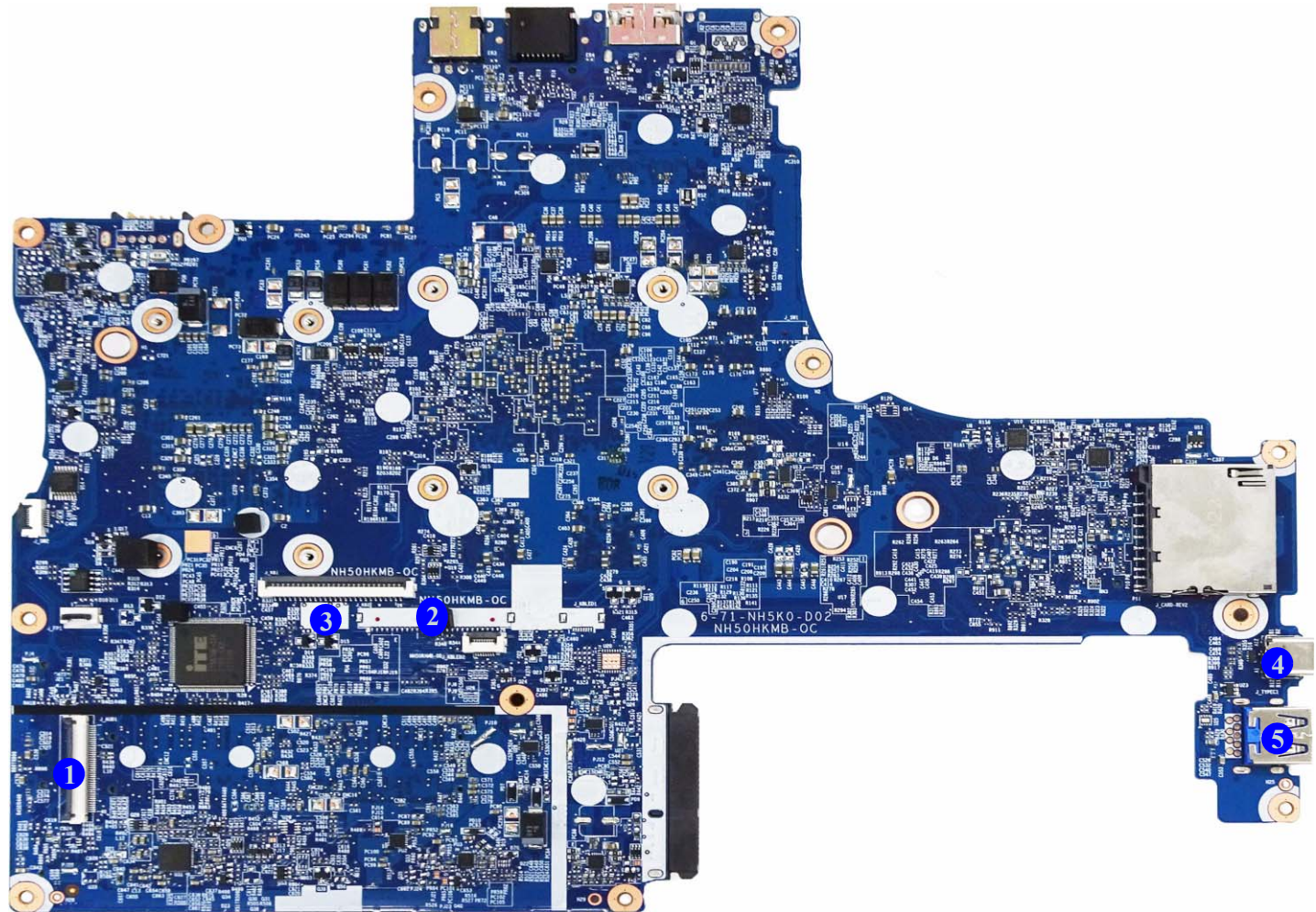

Mainboard Overview - Bottom (Connectors)

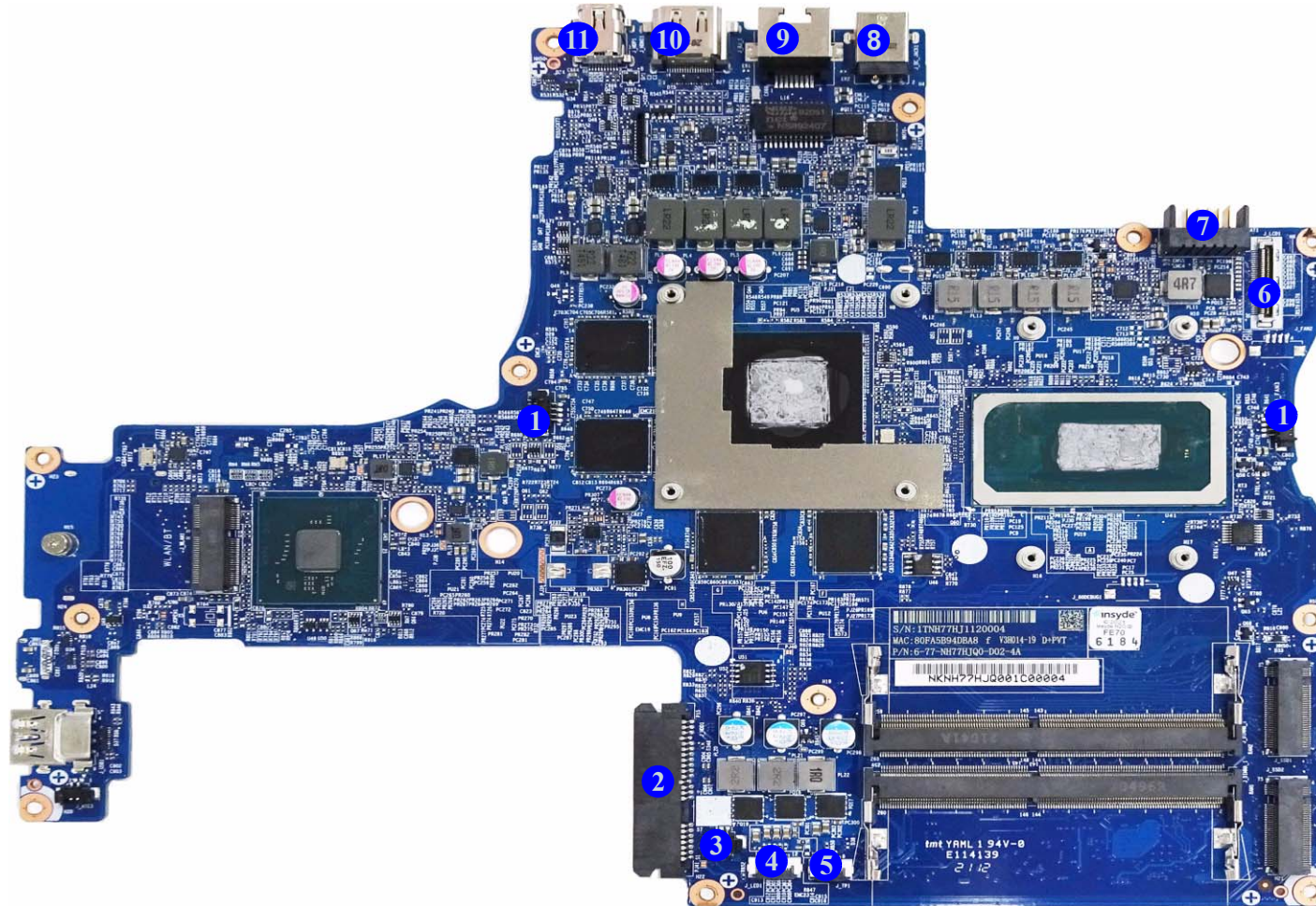

Figure 10
**Mainboard Bottom
Connectors**

1. Fan Connector
2. HDD Connector
3. Speaker Connector
4. LED Connector
5. Touchpad Connector
6. LCD Connector
7. Battery Connector
8. DC-In Jack
9. RJ-45 LAN Jack
10. HDMI-Out Port
11. Mini Display Port 1.4

Chapter 2: Disassembly



Disassembly

Note that for the disassembly of any key parts, **the bottom case must be properly closed before opening the upper part of the LCD** to avoid any damage caused by the nature of the structure.



Overview

This chapter provides step-by-step instructions for disassembling the *NH55HHQ* / *NH55HJQ* / *NH55HKQ* / *NH58HHQ* / *NH58HJQ* / *NH58HKQ* series notebook's parts and subsystems. When it comes to reassembly, reverse the procedures (unless otherwise indicated).

We suggest you completely review any procedure before you take the computer apart.

Procedures such as upgrading/replacing the RAM, optical device and hard disk are included in the User's Manual but are repeated here for your convenience.

To make the disassembly process easier each section may have a box in the page margin. Information contained under the figure # will give a synopsis of the sequence of procedures involved in the disassembly procedure. A box with a  lists the relevant parts you will have after the disassembly process is complete. **Note:** The parts listed will be for the disassembly procedure listed ONLY, and not any previous disassembly step(s) required. Refer to the part list for the previous disassembly procedure. The amount of screws you should be left with will be listed here also.

A box with a  will also provide any possible helpful information. A box with a  contains warnings.

An example of these types of boxes are shown in the sidebar.



Information



Warning

Disassembly

NOTE: All disassembly procedures assume that the system is turned **OFF**, and disconnected from any power supply (the battery is removed too).

Maintenance Tools

The following tools are recommended when working on the notebook PC:

- M3 Philips-head screwdriver
- M2.5 Philips-head screwdriver (magnetized)
- M2 Philips-head screwdriver
- Small flat-head screwdriver
- Pair of needle-nose pliers
- Anti-static wrist-strap



Connections

Connections within the computer are one of four types:

Locking collar sockets for ribbon connectors

To release these connectors, use a small flat-head screwdriver to gently pry the locking collar away from its base. When replacing the connection, make sure the connector is oriented in the same way. The pin1 side is usually not indicated.

Pressure sockets for multi-wire connectors

To release this connector type, grasp it at its head and gently rock it from side to side as you pull it out. Do not pull on the wires themselves. When replacing the connection, do not try to force it. The socket only fits one way.

Pressure sockets for ribbon connectors

To release these connectors, use a small pair of needle-nose pliers to gently lift the connector away from its socket. When replacing the connection, make sure the connector is oriented in the same way. The pin1 side is usually not indicated.

Board-to-board or multi-pin sockets

To separate the boards, gently rock them from side to side as you pull them apart. If the connection is very tight, use a small flat-head screwdriver - use just enough force to start.

Maintenance Precautions

The following precautions are a reminder. To avoid personal injury or damage to the computer while performing a removal and/or replacement job, take the following precautions:

1. **Don't drop it.** Perform your repairs and/or upgrades on a stable surface. If the computer falls, the case and other components could be damaged.
2. **Don't overheat it.** Note the proximity of any heating elements. Keep the computer out of direct sunlight.
3. **Avoid interference.** Note the proximity of any high capacity transformers, electric motors, and other strong magnetic fields. These can hinder proper performance and damage components and/or data. You should also monitor the position of magnetized tools (i.e. screwdrivers).
4. **Keep it dry.** This is an electrical appliance. If water or any other liquid gets into it, the computer could be badly damaged.
5. **Be careful with power.** Avoid accidental shocks, discharges or explosions.
 - Before removing or servicing any part from the computer, turn the computer off and detach any power supplies.
 - When you want to unplug the power cord or any cable/wire, be sure to disconnect it by the plug head. Do not pull on the wire.
6. **Peripherals** – Turn off and detach any peripherals.
7. **Beware of static discharge.** ICs, such as the CPU and main support chips, are vulnerable to static electricity. Before handling any part in the computer, discharge any static electricity inside the computer. When handling a printed circuit board, do not use gloves or other materials which allow static electricity buildup. We suggest that you use an anti-static wrist strap instead.
8. **Beware of corrosion.** As you perform your job, avoid touching any connector leads. Even the cleanest hands produce oils which can attract corrosive elements.
9. **Keep your work environment clean.** Tobacco smoke, dust or other air-borne particulate matter is often attracted to charged surfaces, reducing performance.
10. **Keep track of the components.** When removing or replacing any part, be careful not to leave small parts, such as screws, loose inside the computer.

Cleaning

Do not apply cleaner directly to the computer, use a soft clean cloth.

Do not use volatile (petroleum distillates) or abrasive cleaners on any part of the computer.

(For Computer Models Supplied with Light Blue Cleaning Cloth) Some computer models in this series come supplied with a light blue cleaning cloth. To clean the computer case with this cloth follow the instructions below.

- Power off the computer and peripherals.
- Disconnect the AC/DC adapter from the computer.
- Use a little water to dampen the cloth slightly.
- Clean the computer case with the cloth.
- Dry the computer with a dry cloth, or allow it time to dry before turning on.
- Reconnect the AC/DC adapter and turn the computer on.



Power Safety Warning

Before you undertake any upgrade procedures, make sure that you have turned off the power, and disconnected all peripherals and cables (including telephone lines and power cord). It is advisable to also remove your battery in order to prevent accidentally turning the machine on.

Disassembly Steps

The following table lists the disassembly steps, and on which page to find the related information. **PLEASE PERFORM THE DISASSEMBLY STEPS IN THE ORDER INDICATED.**

To remove the Battery:

1. Remove the battery *page 2 - 5*

To remove the Keyboard:

1. Remove the keyboard *page 2 - 6*

To remove the HDD:

1. Remove the battery *page 2 - 5*
2. Remove the HDD *page 2 - 7*

To remove the System Memory:

1. Remove the battery *page 2 - 5*
2. Remove the HDD *page 2 - 7*
3. Remove the system memory *page 2 - 9*

To remove the M.2 SSD:

1. Remove the battery *page 2 - 5*
2. Remove the HDD *page 2 - 7*
3. Remove the SSD *page 2 - 10*

To remove the Wireless LAN Module:

1. Remove the battery *page 2 - 5*
2. Remove the HDD *page 2 - 7*
3. Remove the WLAN *page 2 - 11*

To remove the CCD Module:

1. Remove the battery *page 2 - 5*
2. Remove the HDD *page 2 - 7*
3. Remove the CCD module *page 2 - 13*

Removing the Battery

1. Turn the computer **off**, and turn it over.
2. Slide the latch **1** in the direction of the arrow (*Figure 1a*).
3. Slide the latch **2** in the direction of the arrow.
4. While holding the latch **2**, lift the battery **3** (*Figure 1b*) out of the compartment (*Figure 1c*).

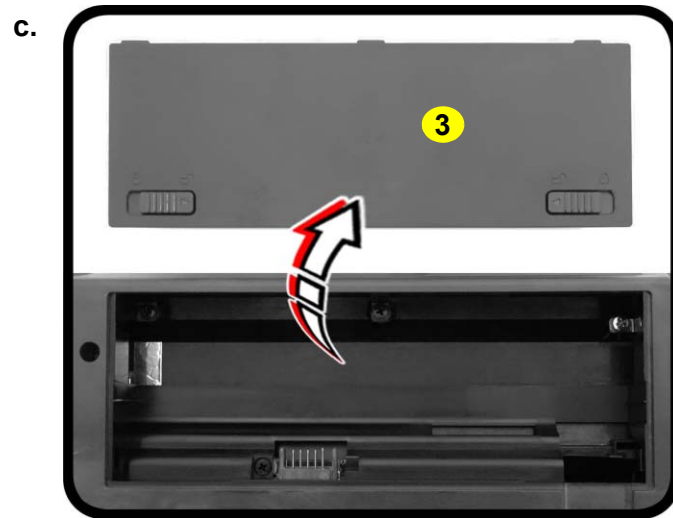
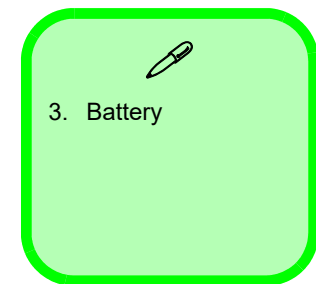

Figure 1
Battery Removal

- a. Slide the latch **1** in the direction of the arrow, and slide the latch **2** in the direction of the arrow.
- b. Lift the battery.
- c. Remove the battery.



Disassembly

Figure 2

Keyboard Removal

- Remove the screws from the bottom of the computer and then eject the keyboard using a special eject stick to push the keyboard out while releasing the keyboard as shown.
- Lift the keyboard up and disconnect the keyboard ribbon cable from the locking collar socket.
- Remove the keyboard.

Removing the Keyboard

- Turn **off** the computer, turn it over.
- Remove screws **1** - **2** from the bottom of the computer.
- Open it up with the LCD on a flat surface before pressing at point **3** to release the keyboard module (use the special eject stick **4** to do this) while releasing the keyboard in the direction of the arrow **5** as shown (**Figure 2a**).
- Carefully lift the keyboard **6** up, being careful not to bend the keyboard ribbon cable **7**. Disconnect the keyboard ribbon cable **7** from the locking collar socket by using a flat-head screwdriver to pry the locking collar pins **8** away from the base (**Figure 2b**).
- Carefully lift the keyboard **6** off the computer (**Figure 2c**).

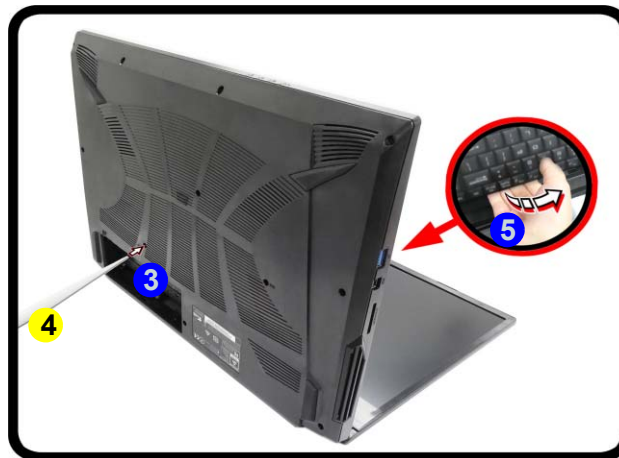
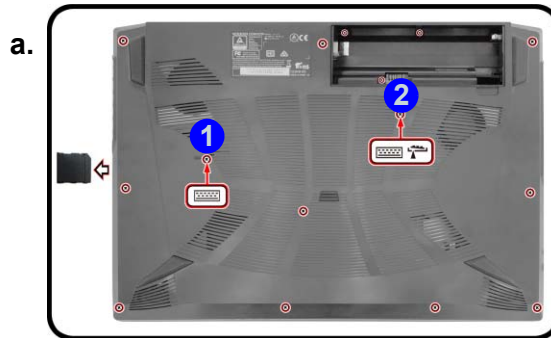

Re-inserting the Keyboard

When re-inserting the keyboard firstly, align the keyboard tabs at the bottom of the keyboard with the slots in the case.



- Eject Stick
- Keyboard

- 2 Screws

Removing the Hard Disk Drive

The hard disk drive can be taken out to accommodate other 2.5" serial (SATA) hard disk drives with a height of 7mm (h). Follow your operating system's installation instructions, and install all necessary drivers and utilities (as outlined in **Chapter 4 of the User's Manual**) when setting up a new hard disk.

Hard Disk Disassembly Process

1. Turn **off** the computer, and remove the battery ([page 2 - 5](#)).
2. Remove the SD card cover **1** and screws **2 - 14** ([Figure 3a](#)).
3. Carefully lift the bottom case **15** up from point **16** and remove it ([Figure 3b](#)).
4. The HDD will be visible at point **17** on the mainboard ([Figure 3c](#)).

Figure 3
HDD Assembly Removal

- Remove the SD card cover and screws.
- Remove the bottom case.
- Locate the HDD.

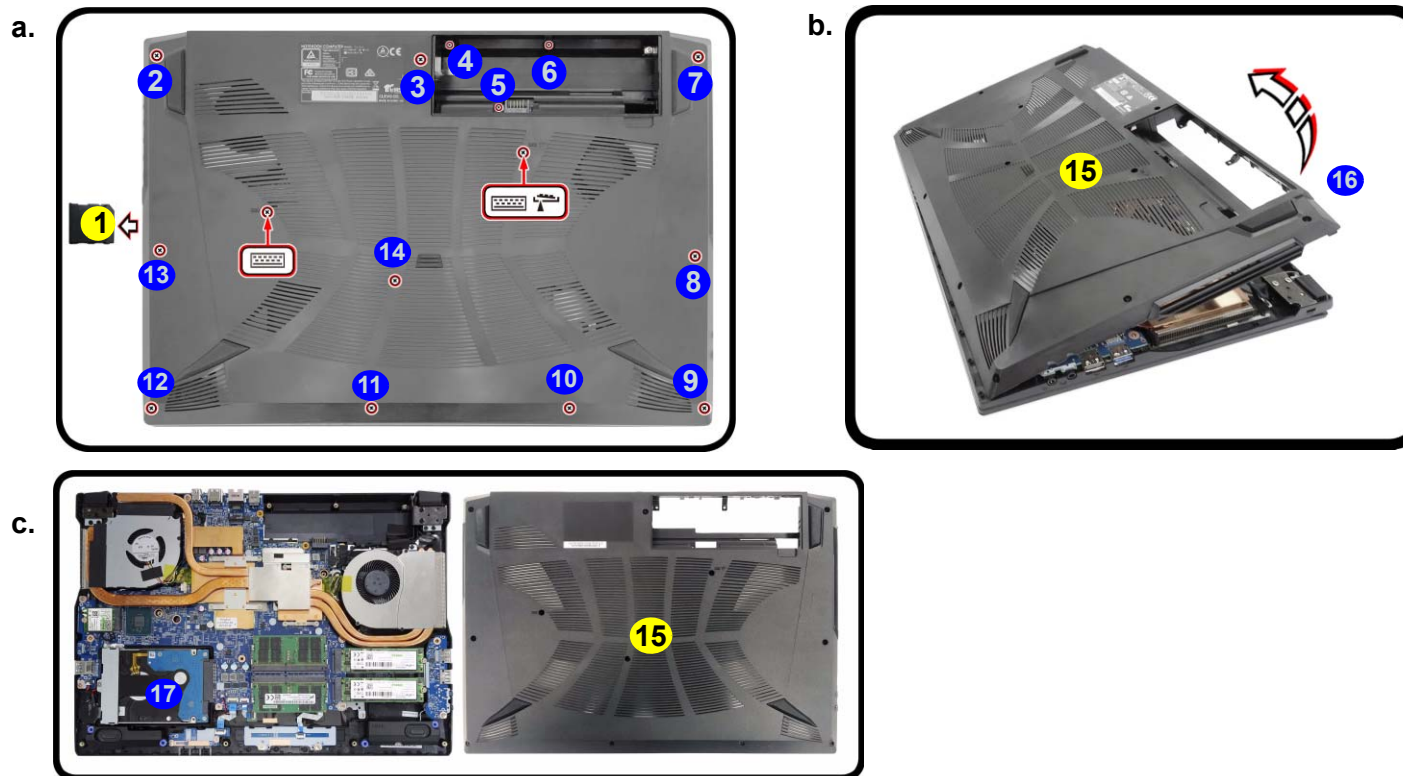



15. Bottom Case

- 13 Screws

Disassembly

Figure 4
**HDD Assembly
 Removal (cont'd.)**

- d. Remove the screw.
- e. Slightly lift and pull the HDD in the direction of the arrow.
- f. Lift the HDD assembly out of the bay.
- g. Remove the screws and bracket from the HDD.

5. Remove screw **18** from the HDD assembly (*Figure 4b*).
6. Slightly lift and pull the hard disk assembly in the direction of arrow **19** (*Figure 4c*).
7. Lift the hard disk assembly **20** out of the bay **21** (*Figure 4d*).
8. Remove screws **22** - **23** and bracket **24** from the hard disk **25** (*Figure 4e*).
9. Reverse the process to install a new hard disk (replace the bottom case by inserting at point **1** first as shown in *Figure 3b*, do not forget to replace the screws).

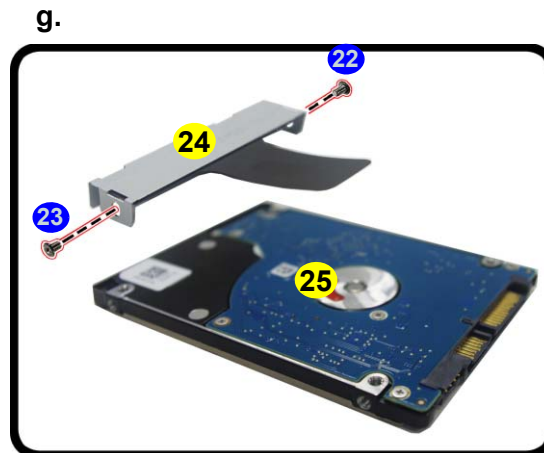
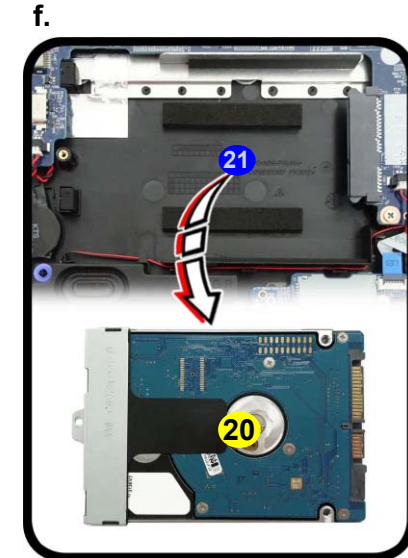
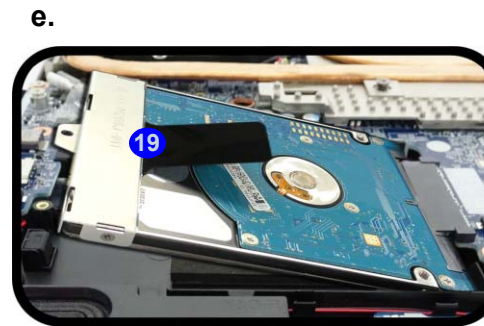
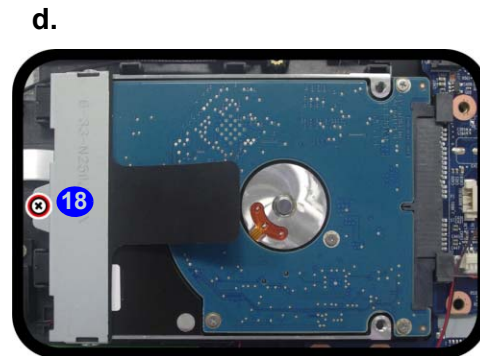

- 
- 20. HDD Assembly
 - 24. Bracket
 - 25. HDD

- 3 Screws



HDD System Warning

New HDD's are blank. Before you begin make sure:

You have backed up any data you want to keep from your old HDD.

You have all the CD-ROMs and FDDs required to install your operating system and programs.

If you have access to the internet, download the latest application and hardware driver updates for the operating system you plan to install. Copy these to a removable medium.

Removing the System Memory (RAM)

The computer has two memory sockets for 260 pin Small Outline Dual In-line Memory Modules (SO-DIMM) supporting DDR4 up to 3200 MHz. The main memory can be expanded up to 32GB. The total memory size is automatically detected by the POST routine once you turn on your computer.

Memory Upgrade Process

1. Turn **off** the computer, turn it over, remove the battery ([page 2 - 5](#)).
2. The RAM modules will be visible at point **1** on the mainboard ([Figure 5a](#)).
3. Gently pull the two release latches (**2** & **3**) on the sides of the memory socket in the direction indicated by the arrows ([Figure 5b](#)). The RAM module **4** will pop-up ([Figure 5c](#)), and you can then remove it.
4. Pull the latches to release the second module if necessary.
5. Insert a new module (**for single module only** - make sure to install it in the top slot "J_DIMMB_1" as shown in [Figure 5c](#)) by holding it at about a 30° angle and fit the connectors firmly into the memory slot.
6. The module will only fit one way as defined by its pin alignment. Make sure the module is seated as far into the slot as it will go. **DO NOT FORCE IT**; it should fit without much pressure.
7. Press the module in and down towards the mainboard until the slot levers click into place to secure the module.
8. Replace the bottom cover and the screws (see [page 2 - 7](#)).
9. Restart the computer to allow the BIOS to register the new memory configuration as it starts up.

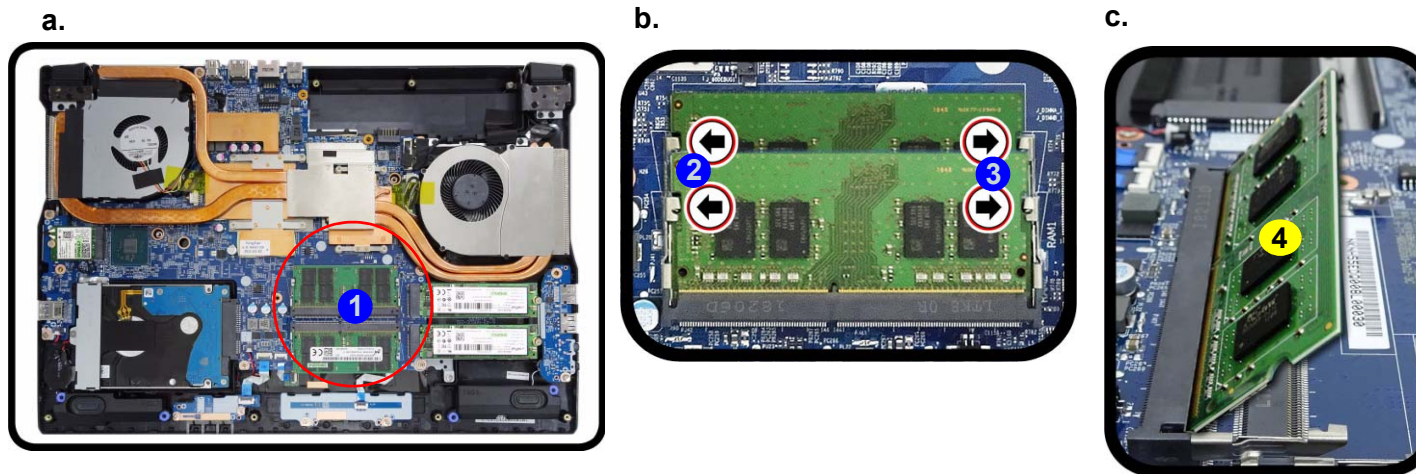

Figure 5
RAM Module Removal

- a. The RAM modules will be visible at point **1** on the mainboard.
- b. Pull the release latches.
- c. Remove the module.



Contact Warning

Be careful not to touch the metal pins on the module's connecting edge. Even the cleanest hands have oils which can attract particles, and degrade the module's performance.



4. RAM Module

Disassembly

Figure 6
M.2 SSD Module
Removal

- Locate the M.2 SSD.
- Remove the screw.
- The M.2 SSD module will pop up.

Removing the M.2 SSD Module

M.2 SSD Module Removal Procedure

- Turn off the computer, turn it over, remove the battery ([page 2 - 5](#)).
- The M.2 SSD module will be visible at point **1** on the mainboard ([Figure 6a](#)).
- Remove the screw **2** ([Figure 6b](#)).
- The M.2 SSD module **3** ([Figure 6c](#)) will pop-up, and you can remove it from the computer.

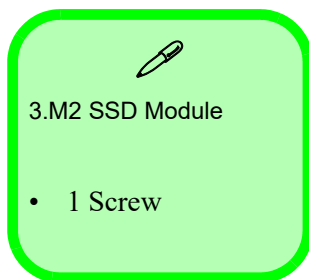
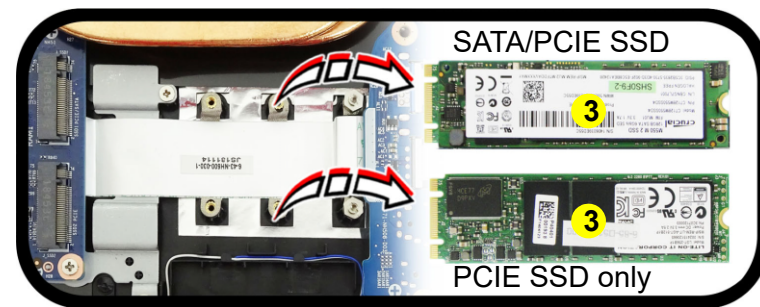
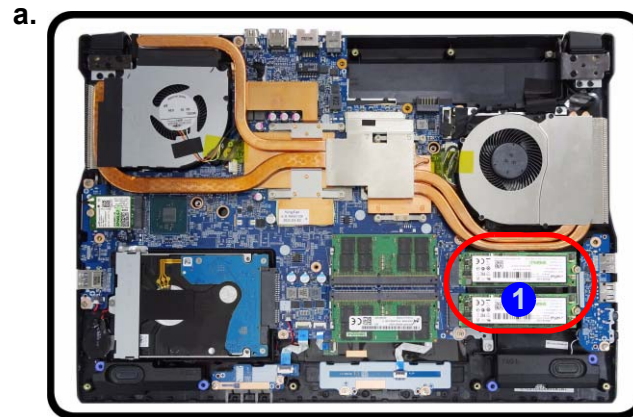

Removing the Wireless LAN Module

1. Turn **off** the computer, turn it over, remove the battery ([page 2 - 5](#)).
2. The Wireless LAN module will be visible at point **1** on the mainboard ([Figure 7a](#)).
3. Remove the mylar cover **2** ([Figure 7b](#)).
4. Carefully disconnect the cables **3** & **4**, and then remove the screw **5** ([Figure 7c](#)).
5. The Wireless LAN module **6** ([Figure 7d](#)) will pop-up, and you can remove it from the computer.
6. Reverse the process to install a new module (do not forget to replace the mylar and screws while making sure the wire are properly placed).

Figure 7
Wireless LAN Module Removal

- a. Locate the WLAN.
- b. Remove the mylar cover.
- c. Disconnect the cables and remove the screw.
- d. The WLAN module will pop up.

Note: Make sure you reconnect the antenna cable to the “1 + 2” socket ([Figure 7b](#)).

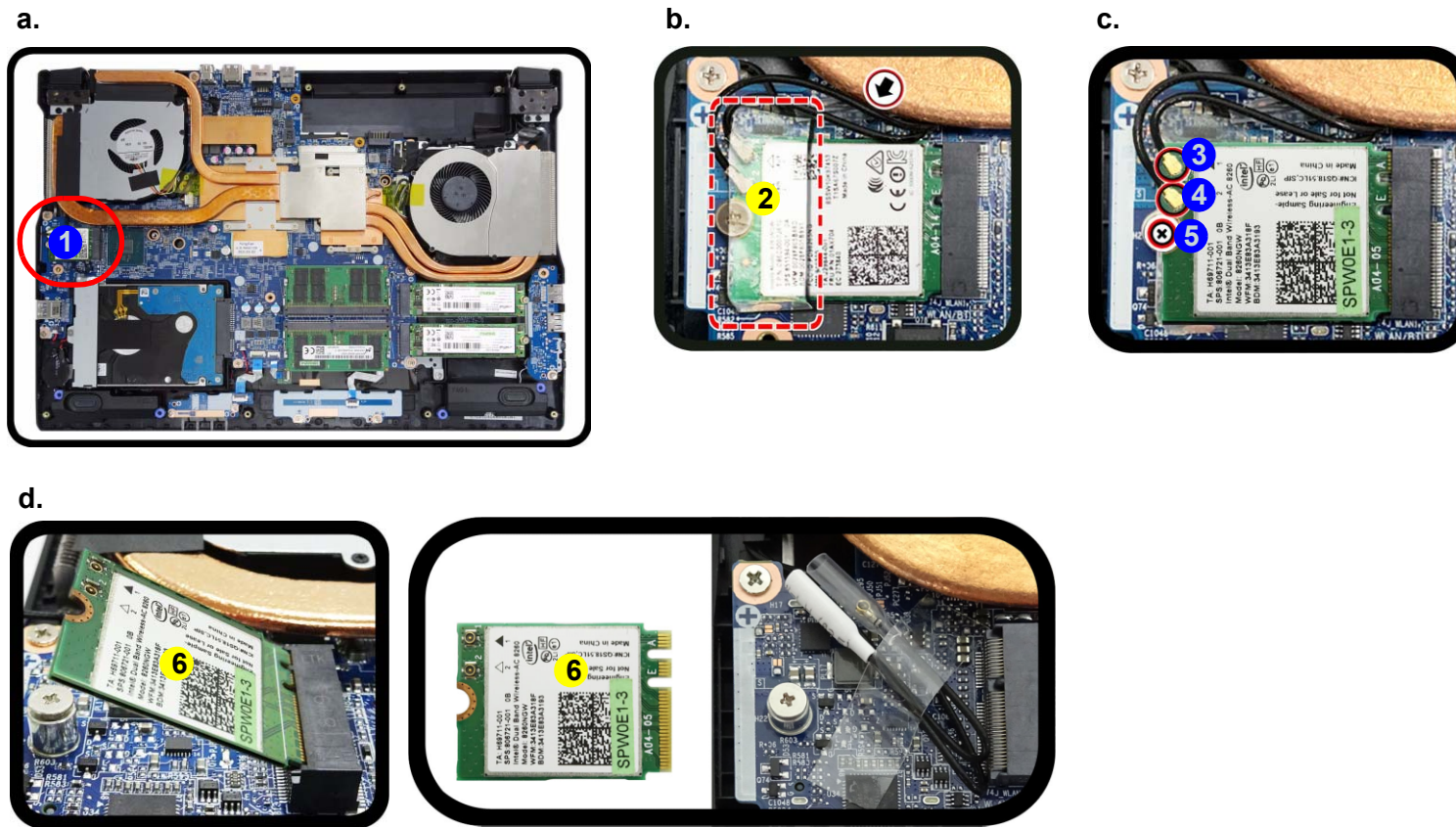

✍️

2. Mylar Cover
6. Wireless LAN Module

- 1 Screw

Wireless LAN, Combo Module Cables

Note that the cables for connecting to the antennae on WLAN, WLAN & Bluetooth Combo modules are not labelled. The cables/covers (each cable will have either a black or transparent cable cover) are color coded for identification as outlined in the table below.

Module Type	Antenna Type	Cable Color	Cable Cover Type
WLAN/WLAN & Bluetooth Combo	WL 1	Black	Transparent
	WL 2	Black	White

Cable 1 is usually connected to antenna 1 on the module, and cable 2 to antenna 2.

Removing the CCD

1. Turn **off** the computer, turn it over to remove the battery ([page 2 - 5](#)).
2. Lay the computer down on a flat surface with the top case up forming a 90 degree angle.
3. Carefully run your fingers around the inner frame of the LCD panel to lift at points **1** - **4** as indicated by the arrows ([Figure 8a](#)).
4. Remove the LCD front cover **5** ([Figure 8b](#)).

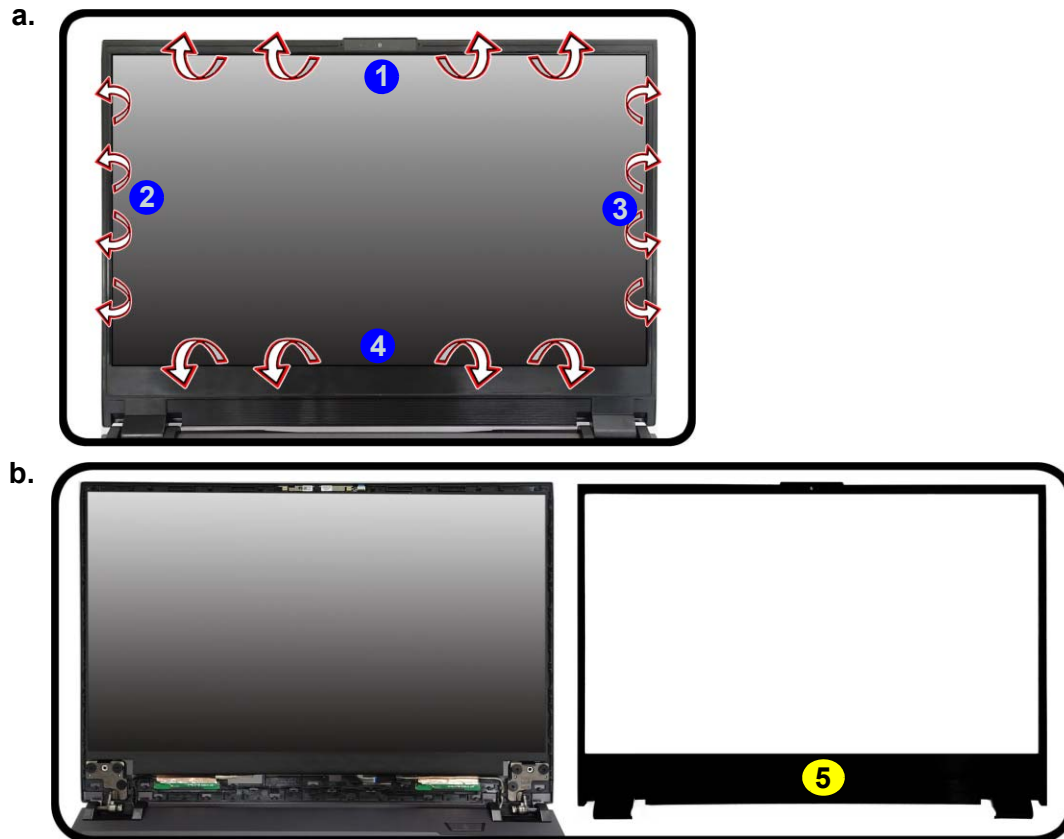

Figure 8
CCD Removal

- a. Carefully release the inner frame of the LCD panel at the points indicated by the arrows.
- b. Remove the LCD front cover.



Disassembly

Figure 9
CCD Removal
(cont'd)

- c. Disconnect the cable from the locking collar socket.
- d. Remove the CCD module.

5. Disconnect the cable **6** from the locking collar socket by using a flat-head screwdriver to pry the locking collar pins **7** away from the base (*Figure 9c*).
6. Remove the CCD module **8** (*Figure 9d*).
7. Reverse the process to install a new CCD module.

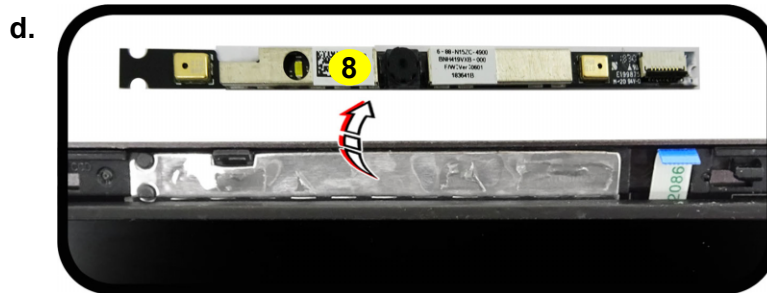

8. CCD Module

Appendix A: Part Lists

This appendix breaks down the *NH55HHQ / NH55HJQ / NH55HKQ / NH58HHQ / NH58HJQ / NH58HKQ* series notebook's construction into a series of illustrations. The component part numbers are indicated in the tables opposite the drawings.

Note: This section indicates the *manufacturer's* part numbers. Your organization may use a different system, so be sure to cross-check any relevant documentation.

Note: Some assemblies may have parts in common (especially screws). However, the part lists DO NOT indicate the total number of duplicated parts used.

Note: Be sure to check any update notices. The parts shown in these illustrations are appropriate for the system at the time of publication. Over the product life, some parts may be improved or re-configured, resulting in *new* part numbers.

Part List Illustration Location

The following table indicates where to find the appropriate part list illustration.

Table A - 1
**Part List Illustration
Location**

Part	NH55HHQ/NH55HJQ/ NH55HKQ	NH58HHQ/NH58HJQ/ NH58HKQ
Top	<i>page A - 3</i>	
Bottom	<i>page A - 4</i>	
Main Board	<i>page A - 5</i>	
HDD	<i>page A - 6</i>	
LCD	<i>page A - 7</i>	<i>page A - 8</i>

Top

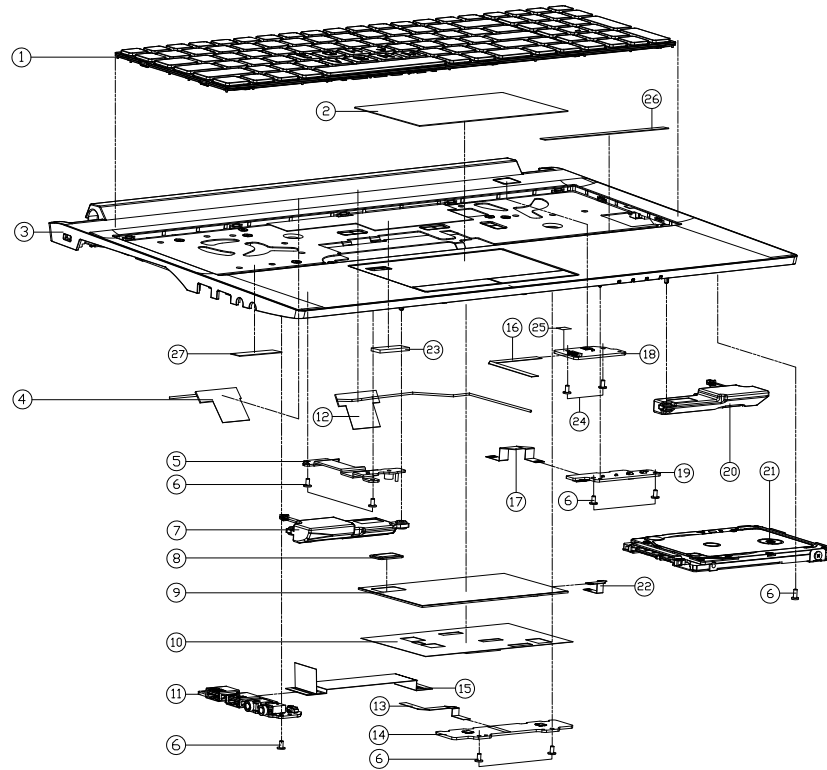

ITEM	PART NAME	PART NO	REMARK
1	KB FOR MULTI 15C BL KB US SERIES NH50ED	6-NH50ED-KB-MCL-US	
2	W/O FP TP MYLAR AG32 NH55EDQ	6-40-NH552-052	
3	TOP CASE MODULE NH55RAQ	6-39-NH552-A14	
4	ANTENNA PEHA WLAN V02 PCB DL 40X5MM 24G/5G/60GZ W/2-300MM NH50P	6-23-7NH5P-020	
5	MB SUPPORT BRKT NH50ED	6-33-NH502-021	
6	SCREW M2X4L KI NI ICT NY (DD=04.5,DT=0.8)	6-35-B1120-4RC	
7	SPK L-CABLE L25X44 2V 4Z L150 MM DS-2514-ML-R2-HF NB707UJ	6-23-5NB70-0L1	
8	TP W/O FP RUBBER (17.9X11.2X1.2T) SILICONE	6-47-N15Z2-090	
9	TOUCH PAD ELAN S4861D-6701C108X6190.86MM NH50DC	6-49-NH5D3-011	
10	TP MYLAR PET NH50ED	6-40-NH502-021	
11	AUDIO BOARD V2.0 NH50HK	6-77-NH5K8-D02	
12	ANTENNA PEHA WLAN V01 PCB DL 40X5MM 24G/5G/60GZ W/1-200MM NH50P	6-23-7NH5P-010	
13	FFC CABLE CLICK TO TP L=61MM 3V 4PIN (GX) NH50ED	6-43-NH500-051	
14	CLICK BOARD V1.0 NH50HK	6-77-NH5K2-D01	
15	FFC CABLE AUDIO TO MB L=102MM 3V 40PIN (GX) NH50ED	6-43-NH500-031	
16	FFC CABLE POWER TO MB L=84MM 3V 4PIN (GX) NH50ED	6-43-NH550-010	
17	FFC CABLE LED TO MB L=58MM 3V 12PIN (GX) NH50ED	6-43-NH500-011	
18	POWER SW BOARD V1.0 NH55HKQ	6-77-NH55S-D41	
19	LED BOARD V1.0 NH50HK	6-77-NH5K4-D01	
20	SPK R-CABLE L25X44 2V 4Z L 200MM DS-2514-ML-R2-HF NB707UJ	6-23-5NB70-0R1	
21	W/O HDD ASS'Y NH70EDQ	6-79-NH70EDQJ-010	
21	W/HDD ASS'Y NH70EDQ	6-79-NH70EDQJ-020	
22	FFC CABLE TP TO MB L=36MM 3V 8PIN (GX) NH50ED	6-43-NH500-041	
23	MLCC THERMAL PAD NH50DD2	6-48-NH5D2-010	
24	SCREW M2X4L KI NI ICT NY (DD=04.5,DT=0.4)	6-35-B1120-4RE	
25	MYLAR(7*6*0.15MM,BLACK) FOR P640RF	6-40-00150-760	
26	MYLAR 90*2.85*0.4 FOR NH55RAQ	6-40-00150-902	
27	FAN SPONGE 40*10*1.05 NH55RAQ-HM	6-47-0019A-40Z	

Figure A - 1
Top

Bottom

Figure A - 2
Bottom

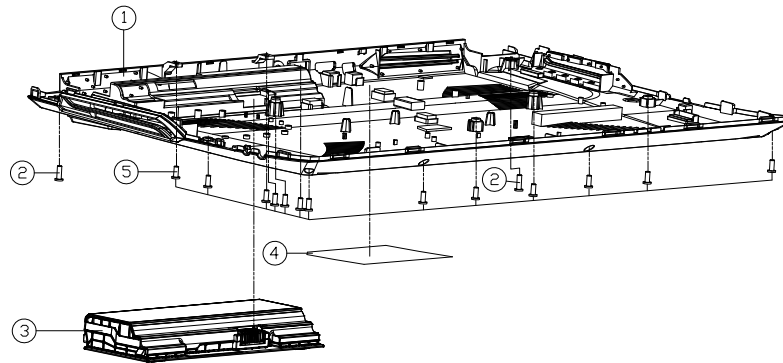

ITEM	PART NAME	PART NO	REMARK
1	BOTTOM CASE MODULE NH55RAQ	6-39-NH553-A13	
2	.SCREW M2.5*8L KI BK/Z NY ICT	6-35-B6125-8R0	
3	BATP S LI 14AV/34HV/48/96WH 4SIP 3MP/30U 0040Z50 98002242H /AB IN50ED	6-87-NH50S-41C01	
3	BATP S LI 14AV/34HV/48/96WH 4SIP CETAC/LG 0040Z50 5413902000 IN50ED	6-87-NH50S-42D01	
3	BATP S LI 14AV/34HV/48/96WH 4SIP CETAC/PANSONIC 0040Z50 5413902000 C270M0	6-87-NH5DS-42H00-1	
4	PRODUCT LABEL "G5 MD" FDR NH55HJQ-Y	6-45-NH558-0H0-Y	
4	PRODUCT LABEL "G5 GD" FDR NH55HKQ-Y	6-45-NH558-0J0-Y	
5	SCREW M2.5*6L K BZ ICT NY	6-35-82125-6RA	

Main Board

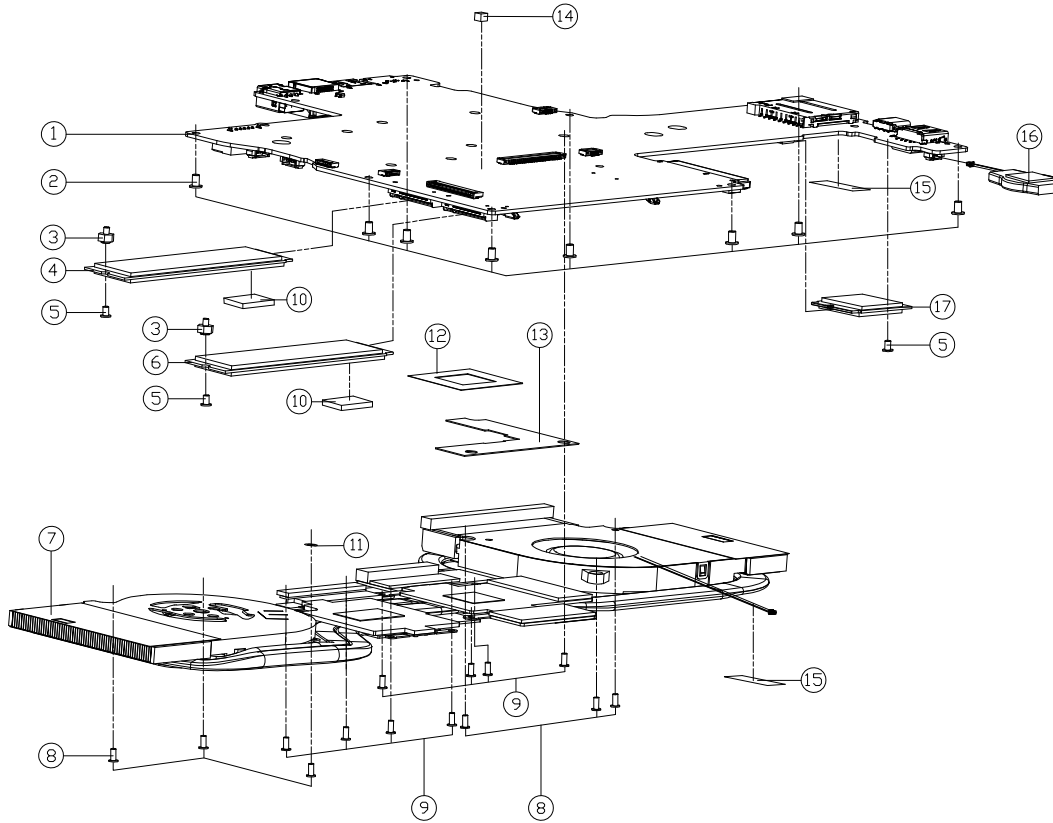

ITEM	PART NAME	PART NO	REMARK
1	MAIN BOARD (P/UP) - 677-NH50HJ00-D02-2A	6-77-NH50HJ00-D02-2A	
1	MAIN BOARD (P/UP) - 677-NH50HJ00-D02-3B	6-77-NH50HJ00-D02-3B	
1	MAIN BOARD (P/UP) - 677-NH50HJ00-D02-1A	6-77-NH50HJ00-D02-1A	
1	MAIN BOARD (P/UP) - 677-NH50HJ00-D02-4D	6-77-NH50HJ00-D02-4D	
1	MAIN BOARD (P/UP) - 677-NH50HJ00-D02-1A	6-77-NH50HJ00-D02-1A	
1	MAIN BOARD (P/UP) - 677-NH50HJ00-D02-2A	6-77-NH50HJ00-D02-2A	
1	MAIN BOARD (P/UP) - 677-NH50HJ00-D02-1B	6-77-NH50HJ00-D02-1B	
1	MAIN BOARD (P/UP) - 677-NH50HJ00-D02-4A	6-77-NH50HJ00-D02-4A	
1	MAIN BOARD (P/UP) - 677-NH50HJ00-D02-4C	6-77-NH50HJ00-D02-4C	
1	MAIN BOARD (P/UP) - 677-NH50HJ00-D02-1A	6-77-NH50HJ00-D02-1A	
1	MAIN BOARD (P/UP) - 677-NH50HJ00-D02-2A	6-77-NH50HJ00-D02-2A	
2	SCREW M2.5x4L (D=4.6, T=8.8) KI NI ICT NY	6-35-B1125-4RA	
3	SOCKET W/25 P/25 STEEL KIT NY FOR MFT CARTRIDGE W/120	6-35-ZA120-2RS-2	
4	SOCKET W/25 P/25 STEEL KIT NY FOR MFT CARTRIDGE W/120	6-85-DS15B-S0C	OPTION
4	SOCKET W/25 P/25 STEEL KIT NY FOR MFT CARTRIDGE W/120	6-85-DS11T-B00	OPTION
4	SOCKET W/25 P/25 STEEL KIT NY FOR MFT CARTRIDGE W/120	6-85-DS15B-B01	OPTION
4	SOCKET W/25 P/25 STEEL KIT NY FOR MFT CARTRIDGE W/120	6-85-DS15B-H07	OPTION
4	SOCKET W/25 P/25 STEEL KIT NY FOR MFT CARTRIDGE W/120	6-85-DS15B-H05	OPTION
4	SOCKET W/25 P/25 STEEL KIT NY FOR MFT CARTRIDGE W/120	6-85-DS15B-T00	OPTION
4	SOCKET W/25 P/25 STEEL KIT NY FOR MFT CARTRIDGE W/120	6-85-DS15B-K00	OPTION
4	SOCKET W/25 P/25 STEEL KIT NY FOR MFT CARTRIDGE W/120	6-85-DS15B-K01	OPTION
4	SOCKET W/25 P/25 STEEL KIT NY FOR MFT CARTRIDGE W/120	6-85-DS15B-I01	OPTION
4	SOCKET W/25 P/25 STEEL KIT NY FOR MFT CARTRIDGE W/120	6-85-DS15B-Z04	OPTION
5	SCREW M2x4L KI NI ICT NY (D=4.5, T=8.8)	6-35-B1120-2RA	
6	SOCKET W/25 P/25 STEEL KIT NY FOR MFT CARTRIDGE W/120	6-85-DS15B-S0C	OPTION
6	SOCKET W/25 P/25 STEEL KIT NY FOR MFT CARTRIDGE W/120	6-85-DS11T-B00	OPTION
6	SOCKET W/25 P/25 STEEL KIT NY FOR MFT CARTRIDGE W/120	6-85-DS15B-B01	OPTION
6	SOCKET W/25 P/25 STEEL KIT NY FOR MFT CARTRIDGE W/120	6-85-DS15B-H07	OPTION
6	SOCKET W/25 P/25 STEEL KIT NY FOR MFT CARTRIDGE W/120	6-85-DS15B-H05	OPTION
6	SOCKET W/25 P/25 STEEL KIT NY FOR MFT CARTRIDGE W/120	6-85-DS15B-T00	OPTION
6	SOCKET W/25 P/25 STEEL KIT NY FOR MFT CARTRIDGE W/120	6-85-DS15B-K00	OPTION
6	SOCKET W/25 P/25 STEEL KIT NY FOR MFT CARTRIDGE W/120	6-85-DS15B-K01	OPTION
6	SOCKET W/25 P/25 STEEL KIT NY FOR MFT CARTRIDGE W/120	6-85-DS15B-Z04	OPTION
7	THERMAL MODULE (HEATSINK + FAN PUMP W/10MM) N50SK	6-31-NH5K2-101	
8	SCREW M2x5L (D=4.0, T=8.0) BK/2 ICT NY	6-35-B6120-5R0	
9	SCREW METAL KI NI ICT NY (D=4.5, T=8.8)	6-35-B1120-4RC	
10	THERMAL PAD MAS001 (12x12x0.25) NH50ED	6-48-NH50S-010	
11	WASHER (6x6x0.6) NYLON FOR 30°C (1.8x0.6x0.6)	6-37-02000-603	
12	VGA NI8P MYLAR NH50RA	6-40-NH5ES-010	
13	EMI ABSORBER L 53.0x56.7x0.3(CT) NH50HK	6-47-NH5KS-010	
14	RUBBER (4x4x3.2T) FDR MB NH50ED	6-47-NH50E-050	
15	TAPE MYLAR (C) MYLAR M550J	6-40-M55J2-030	
16	MTL 2000 3V 2200MH V(DRIVE) SUPP (8000000000000000)	6-23-22015-TE0	
17	HEAT SINK (10x10x10) FOR 30°C (1.8x0.6x0.6)	6-88-N15CF-4210	OPTION
17	HEAT SINK (10x10x10) FOR 30°C (1.8x0.6x0.6)	6-88-N24GF-4200	OPTION
17	HEAT SINK (10x10x10) FOR 30°C (1.8x0.6x0.6)	6-88-X17KF-4210	OPTION
17	HEAT SINK (10x10x10) FOR 30°C (1.8x0.6x0.6)	6-88-NV40F-4210	OPTION

Figure A - 3
Main Board

HDD

Figure A - 4
HDD

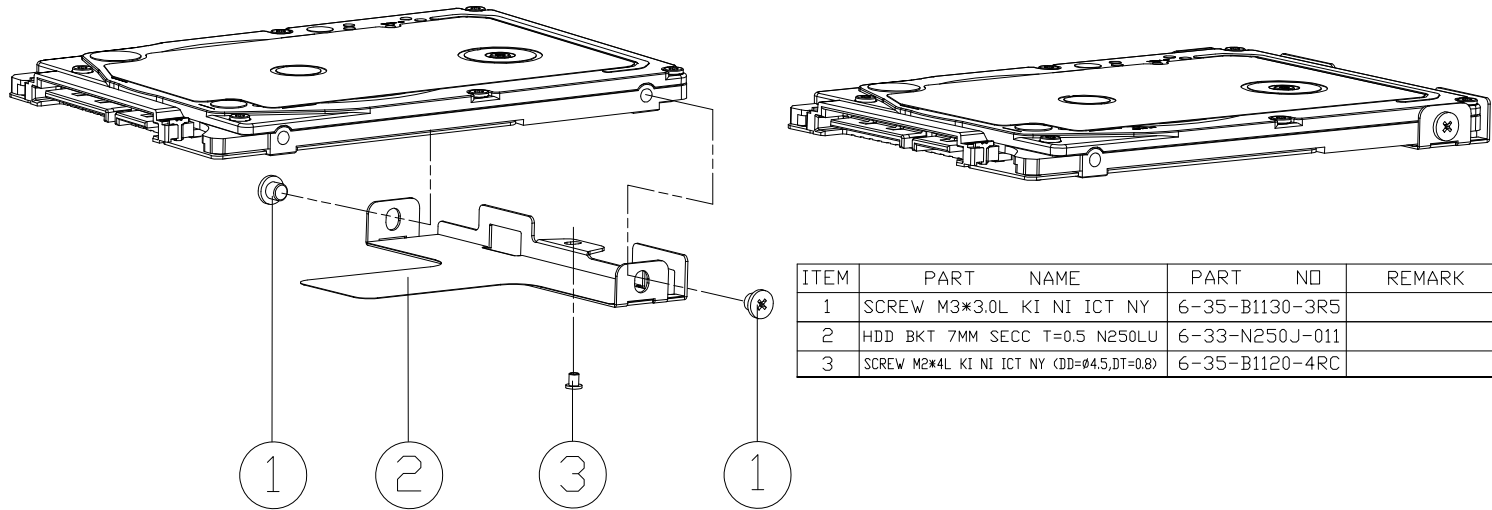

ITEM	PART NAME	PART NO	REMARK
1	SCREW M3*3.0L KI NI ICT NY	6-35-B1130-3R5	
2	HDD BKT 7MM SECC T=0.5 N250LU	6-33-N250J-011	
3	SCREW M2*4L KI NI ICT NY (DD=0.45,DT=0.8)	6-35-B1120-4RC	

LCD (NH55HHQ/NH55HJQ/NH55HKQ)

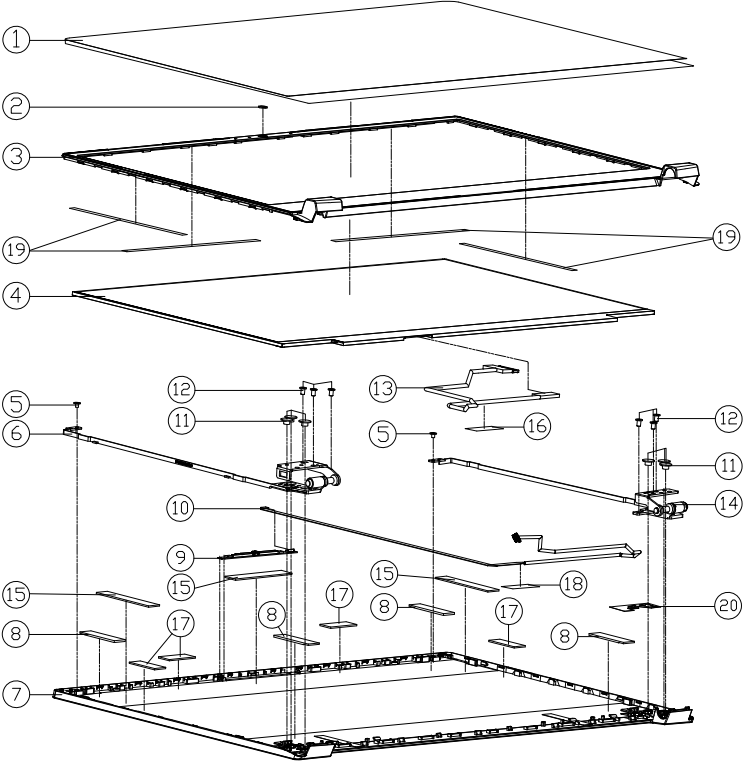

ITEM	PART NAME	PART NO	REMARK
1	LCD PROTECT CLOTH NH55EDQ	6-44-NH558-010	
2	CCD LENS PMMA (DIAMETER 3.6MM) (MP1) P970EN	6-42-P97N1-011-1	
3	LCD FRONT COVER MODULE (GIGABYTE "GIGABYTE") NH55DPQ-Y (KAPDK)	6-39-NH501-014-G1	
4	LCD NS56 FHD/AVA/24HZ/N7/NCN G7/ EDP SHARP LG56LNVA0 1LED 26MM FDR 非紫	6-950-LBB26-A141-Y	
5	SCREW M2*3L KI BZ ICT NY (DD=Ø4.5,DT=0.4)	6-35-B6120-3RD	
6	HINGE L (SK7) NH55EDQ	6-33-NH551-0L1	
7	LCD BACK COVER MODULE (GIGABYTE "GIGABYTE") NH55DPQ-Y (KAPDK)	6-39-NH551-024-G2	
8	LCD BACK SPONGE DOWN (30*10*1.2) (DS-10-CR43824FM92822K) NH55EDQ	6-47-0019A-C02-1	
9	UV CUREM CHROM FILM (60*10*1.5) IN HD D9754 NS20 FUSION WHITE-LED V29-MC0000000000000000	6-88-N15ZC-5100	OPTION
9	UV CUREM CHROM FILM (60*10*1.5) IN HD D9754 NS20 FUSION WHITE-LED V29-MC0000000000000000	6-88-N15ZC-4900	OPTION
9	UV CUREM CHROM FILM (60*10*1.5) IN HD D9754 NS20 FUSION WHITE-LED V29-MC0000000000000000	6-88-N15ZC-5102	OPTION
10	CCD CABLE L=550MM 30V 8PIN (HL) ADD MARK LABEL NH50ED	6-43-NH50T-011	
11	SCREW M2.5*2.5L KI BK/Z ICT NY(Ø8,T=0.6)	6-35-B6125-2R5	
12	SCREW M2.5*4L (D=4.6,T=0.8) KI NI ICT NY	6-35-B1125-4RA	
13	CONTRL. CABLE FOR EDP 30MM 1 30V 4PIN (SHARP 156 24HZ) (H/A/V CON LV6500-224) P800C	6-43-PB501-R10-1N	
14	HINGE R (SK7) NH55EDQ	6-33-NH551-0R1	
15	LCD SPONGE (60*10*1.5T) SM55 P970EN	6-47-0019A-60U	
16	MYLAR (15*5*0.25T) FDR M/B N745WU-N	6-40-N7452-050-N	
17	LCD SPONGE (SM55 25*10*1-5T) NH55EDQ	6-47-0019A-25Q	
18	TOP CASE MYLAR FR83 25*7*0.05 P180HM	6-40-P1802-030	
19	FRONT COVER GLUE UB-D (NITTO 5000 135*3*0.15) FDR W655SZ	6-40-W6551-040	
20	GASKET FOR GPU POWER (33.2*15.95*0.1) NH50HK	6-47-NH5K1-011	

Figure A - 5
LCD (NH55HHQ/
NH55HJQ/
NH55HKQ)

A.Part Lists

LCD (NH58HHQ/NH58HJQ/NH58HKQ)

Figure A - 6
LCD (NH58HHQ/
NH58HJQ/
NH58HKQ)

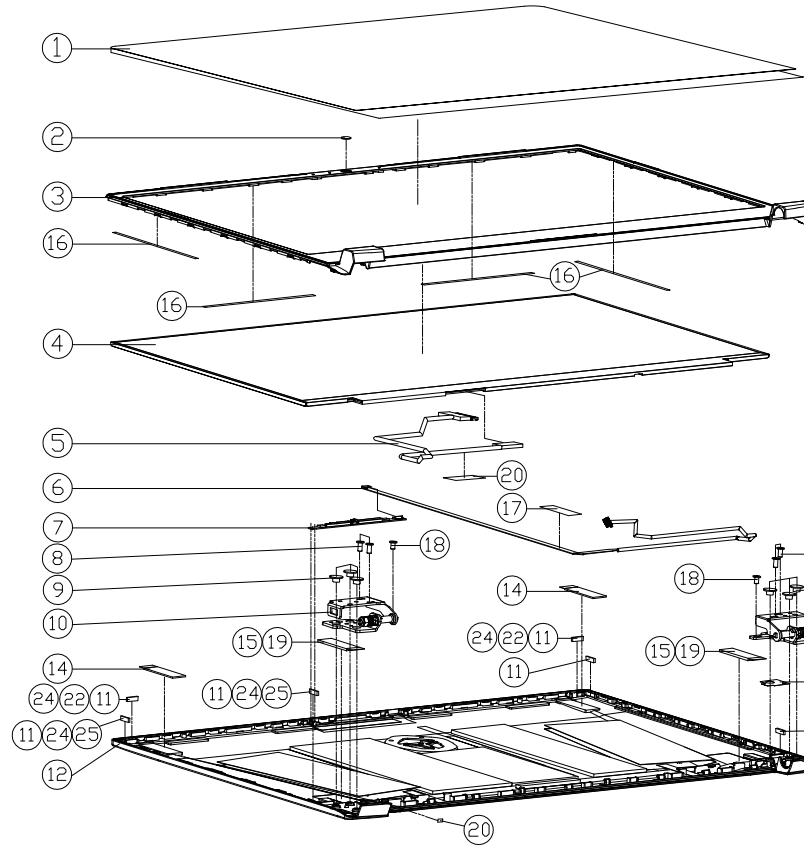

ITEM	PART NAME	PART NO	REMARK
1	LCD PROTECT MYLAR BOPP N150ZU	6-40-N15Z8-010	
2	CCD LENS PMMA (DIAMETER: 3.6MM) (MPI) P970EN	6-42-P97N1-011-1	
3	LCD FRONT COVER MODULE NH50ED	6-39-NH501-014	
4	LCD NIS6' FHD/VVA/24HZ/74/NDN GT/ EDP SHARP L056MLW03 LLED 28MM	6-50-LBB32-L01A	
4	LCD NIS6' FHD/VVA/17/NDN GT/ EDP SHARP X056FHM-N61 LLED 259MM	6-50-LBB25-A020	
4	LCD NIS6' FHD/VVA/144Z/74/NDN GT/EDP AU B156HAN08.4 32MM	6-50-LBB32-G170	
5	WIRE CABLE FOR EDP 4K 300MM 30V 1 30 PIN (CM/L/W CON/LV-D-430L/MSD) P160E1	6-43-PB501-032-1N	FDR 6-50-LBB32-L01A 6-50-LBB25-A020
5	WIRE CABLE FOR EDP 4K 300MM (D 19V 30PIN (CM/L/W CON/LV-D0902-HF) N58BL)	6-43-N85H1-010-2S	FDR 6-50-LBB32-G170
6	CCD CABLE L=550MM 30V 8PIN (HL) ADD MARK LABEL NH50ED	6-43-NH50T-011	
7	UV CURABLE COATING (FRONT) C17022003010 IN 10 VPS-MC 140Z (VPSX N581) F1203 VWHITE-LED	6-88-N15ZC-5102	OPTION
7	UV CURABLE COATING (FRONT) C17022003010 IN 10 VPS-MC 140Z (VPSX N581) F1203 VWHITE-LED	6-88-N15ZC-4900	OPTION
7	UV CURABLE COATING (FRONT) C17022003010 IN 10 VPS-MC 140Z (VPSX N581) F1203 VWHITE-LED	6-88-N15ZC-5100	OPTION
8	SCREW M2.5*6L K BZ ICT NY	6-35-82125-6RA	
9	SCREW M2.5*2.5L KI BK/Z ICT NY(Ø8,T=0.6)	6-35-B6125-2R5	
10	HINGE L MODULE NH58EDQ	6-33-NH581-L01	
11	LCD RUBBER (Ø*2.5*1.45T) SILICON BLACK NH58EDQ	6-47-NH581-041	FDR 6-50-LBB32-L01A 6-50-LBB25-A020
12	LCD BACK COVER MODULE NH58EDQ	6-39-NH581-023	
13	HINGE R MODULE NH58EDQ	6-33-NH581-R01	
14	LALATAPE FOR 026 PANEL (35*10*1.8T) PBS0EF	6-47-PB501-030-1	FDR 6-50-LBB25-A020
15	LCD BACK SPONGE DOWN (30*10*1.2) (DS-10)CR4382+MR2820 NH58EDQ	6-47-0019A-C02-1	
16	FRONT COVER GLUE UGD (UNIT) 5000 (35*3*0.15) FOR W65SSZ	6-40-W6551-040	
17	TOP CASE MYLAR FR83 25*7*0.05 P180HM	6-40-P1802-030	
18	SCREW M2.5*4L (D=4.6,T=0.8) KI NI ICT NY	6-35-B1125-4RA	
19	LCD LALA SPONGE (35*10*0.75T) F1928222K+CR4832 NH58EDQ	6-47-0019A-35R-1	FDR 6-50-LBB32-L01A 6-50-LBB32-G170
20	MYLAR (15*5*0.25T) FOR M/B N745WU-N	6-40-N7452-050-N	
21	MYLAR(7*6*0.15MM, BLACK) FOR P640RF	6-40-00150-760	
22	LCD RUBBER (Ø*2.5*1.2T) SILICON BLACK NH58EDQ	6-47-NH581-051	
23	GASKET FOR GPU POWER 2 (17*12.3*0.1) NH50HK	6-47-NH5K1-020	
24	LCD RUBBER (Ø*2.5*1.45T) SILICON BLACK NH58EDQ	6-47-NH581-041	FDR 6-50-LBB32-G170
25	LCD STOP RUBBER(YELLOW) 5*2.81.65 NV40MC-DV	6-47-NV401-010-DV	FDR 6-50-LBB32-G170

Appendix B: Schematic Diagrams

This appendix has circuit diagrams of the *NH55HHQ/NH55HJQ/NH55HKQ/NH58HHQ/NH58HJQ/NH58HKQ* notebook's PCB's. The following table indicates where to find the appropriate schematic diagram.

Diagram - Page	Diagram - Page	Diagram - Page	Diagram - Page
<i>System Block Diagram - Page B - 2</i>	<i>DDR4 SO_DIMM_1 - Page B - 20</i>	<i>Card Reader & LAN_RTL5227S - Page B - 38</i>	<i>VCCIN_AUX - Page B - 56</i>
<i>Processor 1/8 - Page B - 3</i>	<i>VGA PCI Express - Page B - 21</i>	<i>LAN RTL8111H RTD3 - Page B - 39</i>	<i>DDR 1.2V/0.6VS, 2.5V - Page B - 57</i>
<i>Processor 2/8 - Page B - 4</i>	<i>GPU Frame Buffer A/B - Page B - 22</i>	<i>USB Type-A - Page B - 40</i>	<i>NVVDD1 - Page B - 58</i>
<i>Processor 3/8 - Page B - 5</i>	<i>Frame Buffer A - Page B - 23</i>	<i>USB Type-C - Page B - 41</i>	<i>NVVDD2 - Page B - 59</i>
<i>Processor 4/8 - Page B - 6</i>	<i>Frame Buffer A - Page B - 24</i>	<i>M.2 PCIE 4X/SATA SSD - Page B - 42</i>	<i>PEX_VDD - Page B - 60</i>
<i>Processor 5/8 - Page B - 7</i>	<i>Frame Buffer B - Page B - 25</i>	<i>M.2 WLAN+BT, PCIE 4X SSD - Page B - 43</i>	<i>FBVDDQ - Page B - 61</i>
<i>Processor 6/8 - Page B - 8</i>	<i>Frame Buffer B - Page B - 26</i>	<i>HDD, Click TP, Audio - Page B - 44</i>	<i>OVRM - Page B - 62</i>
<i>Processor 7/8 - Page B - 9</i>	<i>VGA NVVDD Coupling - Page B - 27</i>	<i>LED, CCD, Power SW Bd. - Page B - 45</i>	<i>Click Board - Page B - 63</i>
<i>Processor 8/8 - Page B - 10</i>	<i>Straps and XTAL - Page B - 28</i>	<i>KBC-ITE IT5570 - Page B - 46</i>	<i>LED Board - Page B - 64</i>
<i>PCH 1/8 - Page B - 11</i>	<i>IFP I/O Interface - Page B - 29</i>	<i>RGB KB, Fan - Page B - 47</i>	<i>Audio Board - Page B - 65</i>
<i>PCH 2/8 - Page B - 12</i>	<i>Misc - GPIO, I2C and ROM - Page B - 30</i>	<i>VDD3, VDD5 - Page B - 48</i>	<i>Audio Board + Redriver - Page B - 66</i>
<i>PCH 3/8 - Page B - 13</i>	<i>NVIDIA Power Sequence - Page B - 31</i>	<i>1V8_RUN/AON, NV3V3, 3.3VS - Page B - 49</i>	<i>NH77 PW Board - Page B - 67</i>
<i>PCH 4/8 - Page B - 14</i>	<i>GPU NVVDD, FBVDDQ - Page B - 32</i>	<i>3V, 5V, 3VS, 5VS - Page B - 50</i>	<i>NH50 PW Board - Page B - 68</i>
<i>PCH 5/8 - Page B - 15</i>	<i>GPU GND - Page B - 33</i>	<i>VCCST, VCCSTG, 1.8VS - Page B - 51</i>	<i>NH55 PW Board - Page B - 69</i>
<i>PCH 6/8 - Page B - 16</i>	<i>Panel - Page B - 34</i>	<i>VNN/V1.05 - Page B - 52</i>	<i>Power Sequence - Page B - 70</i>
<i>PCH 7/8 - Page B - 17</i>	<i>mDP - Page B - 35</i>	<i>VCCIN - Page B - 53</i>	<i>Power Map - Page B - 71</i>
<i>PCH 8/8 - Page B - 18</i>	<i>HDMI - Page B - 36</i>	<i>VCCIN Output - Page B - 54</i>	
<i>DDR4 SO_DIMM_0 - Page B - 19</i>	<i>Audio Codec - Page B - 37</i>	<i>AC_In, Charger - Page B - 55</i>	

Table B - 1
**SCHEMATIC
DIAGRAMS**



Version Note

The schematic diagrams in this chapter are based upon version 6-7P-NH5K8-002. If your mainboard (or other boards) are a later version, please check with the Service Center for updated diagrams (if required).

System Block Diagram

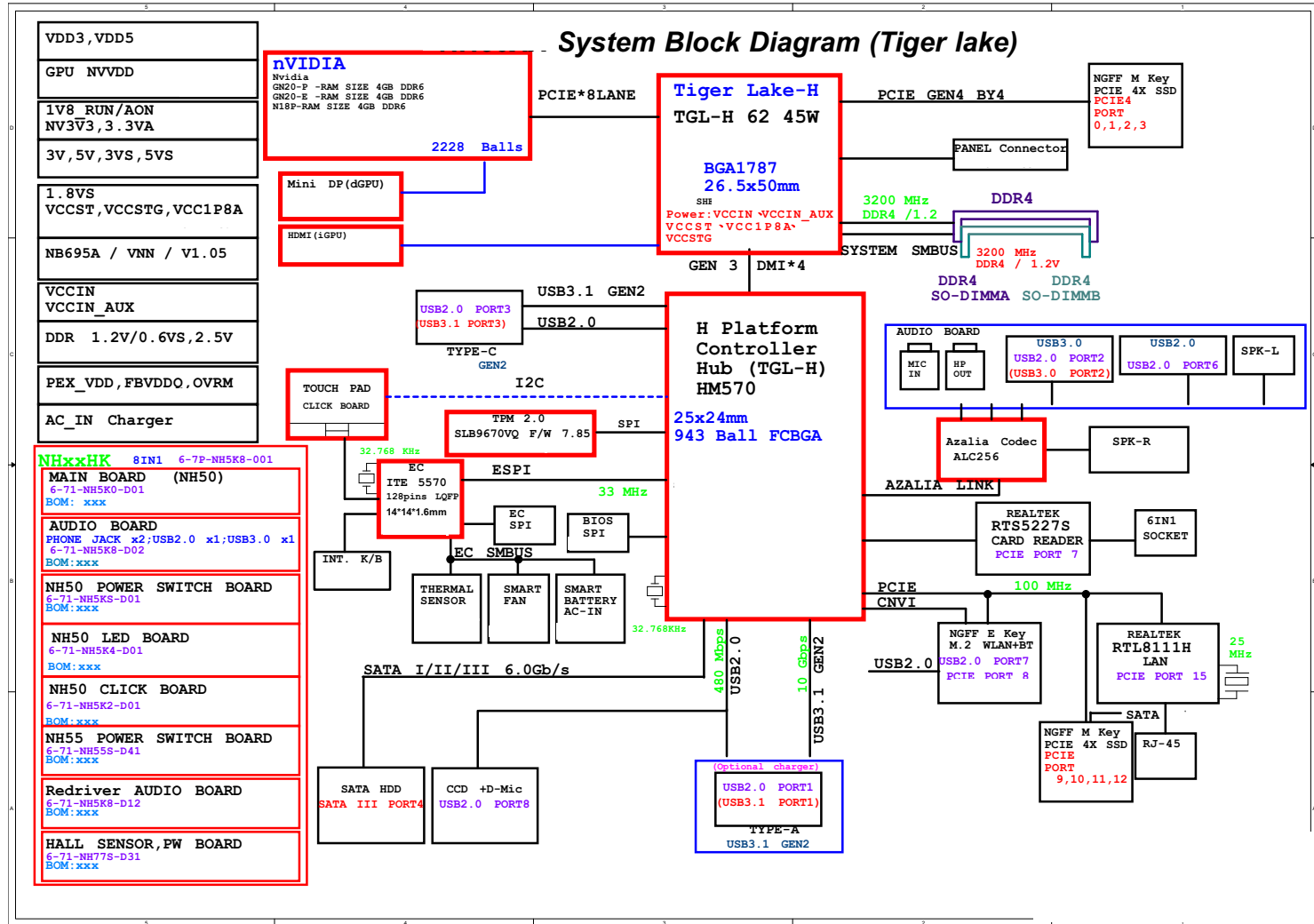

Sheet 1 of 75
System Block
Diagram

Processor 2/8

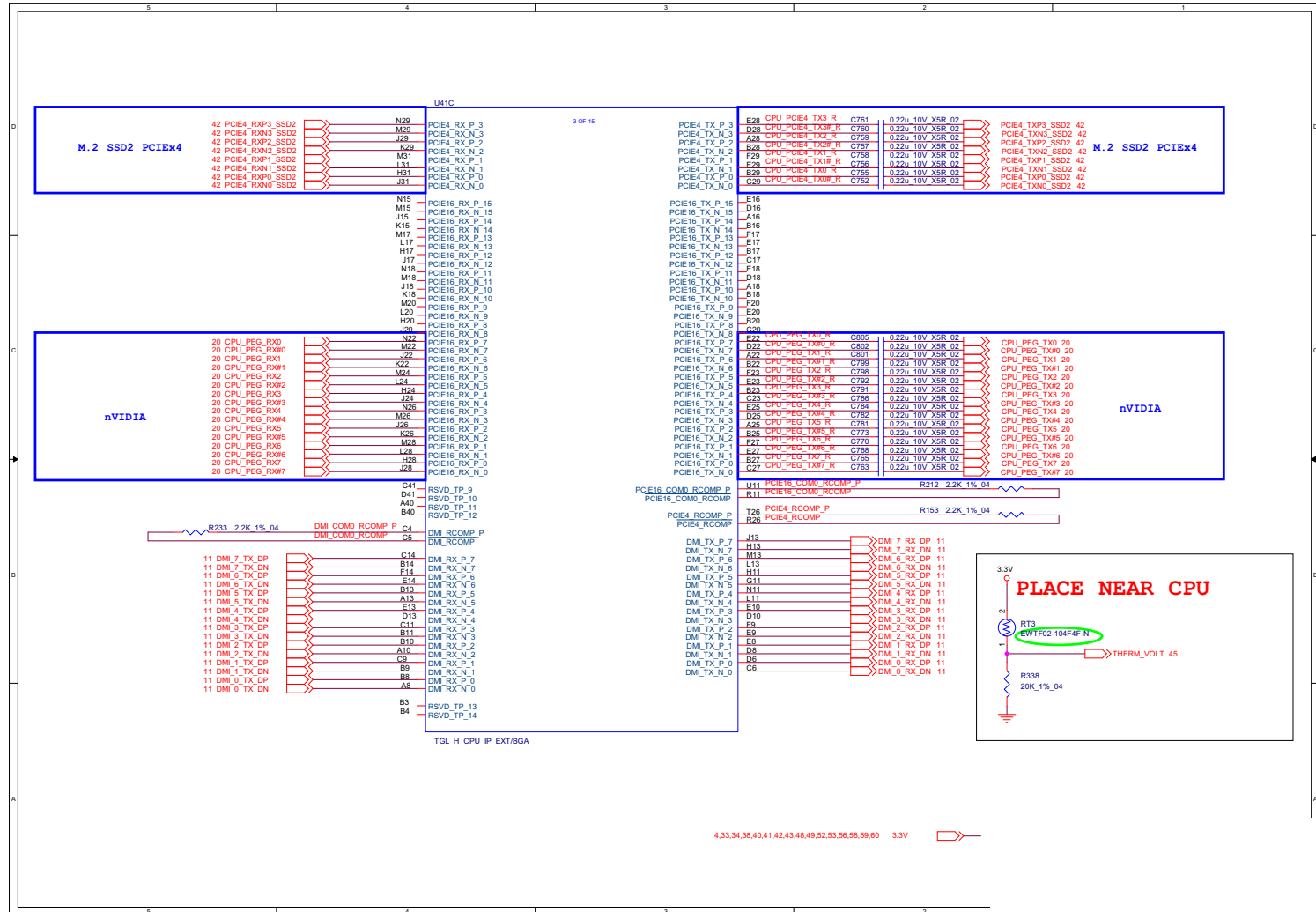

Processor 4/8

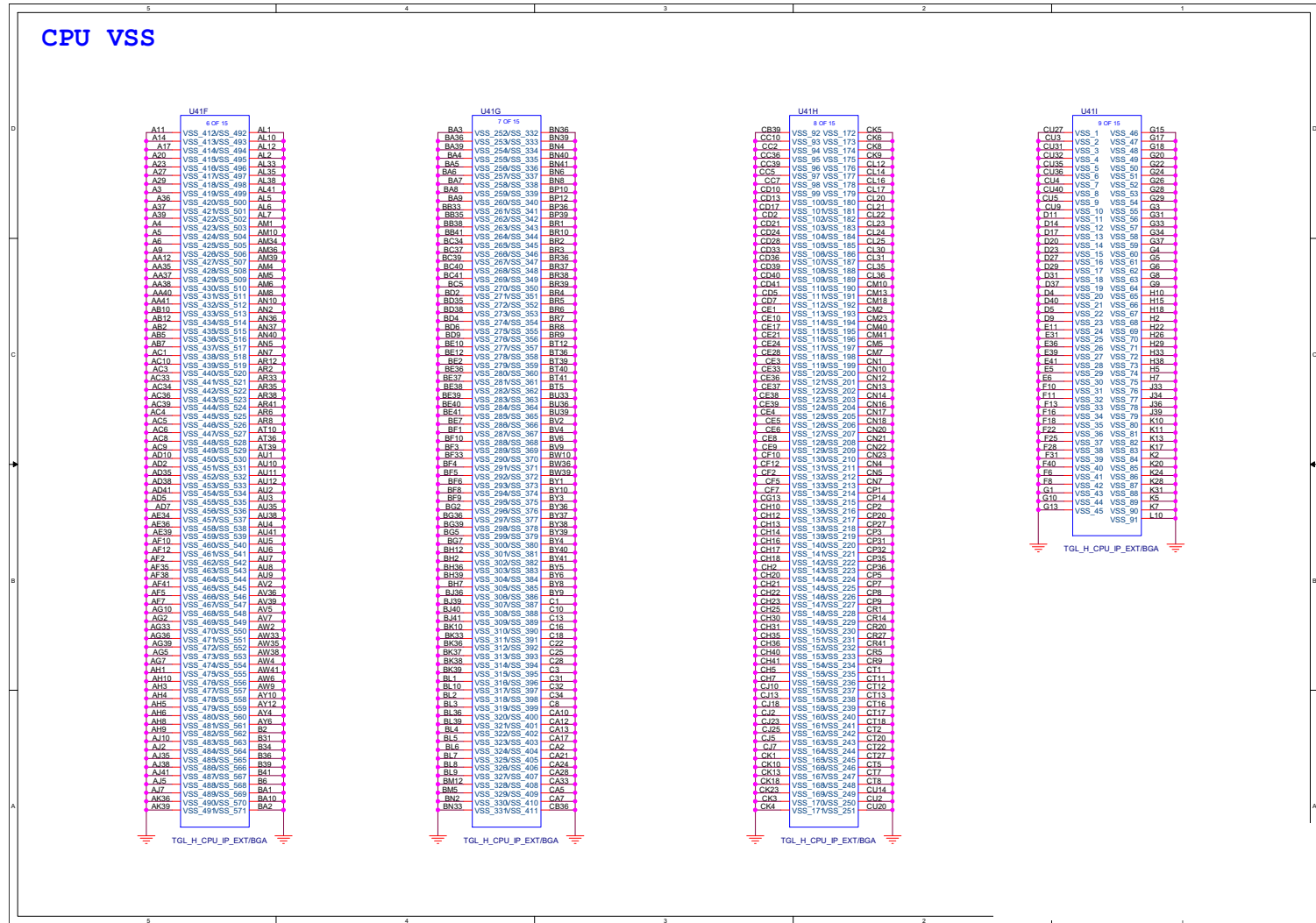

B.Schematic Diagrams

Sheet 5 of 70
Processor 4/8

Processor 5/8

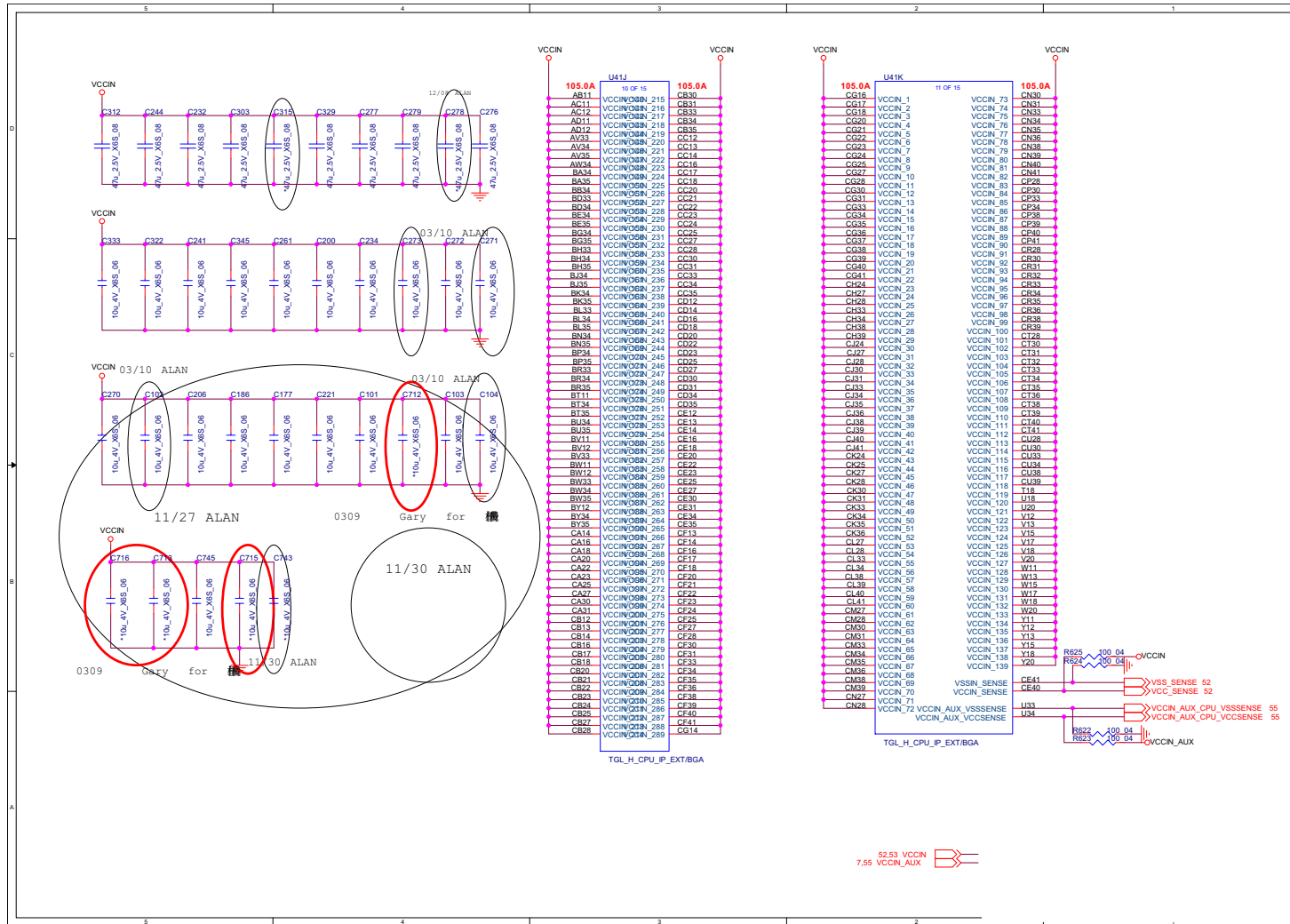

B.Schematic Diagrams

Sheet 6 of 70
Processor 5/8

Processor 6/8

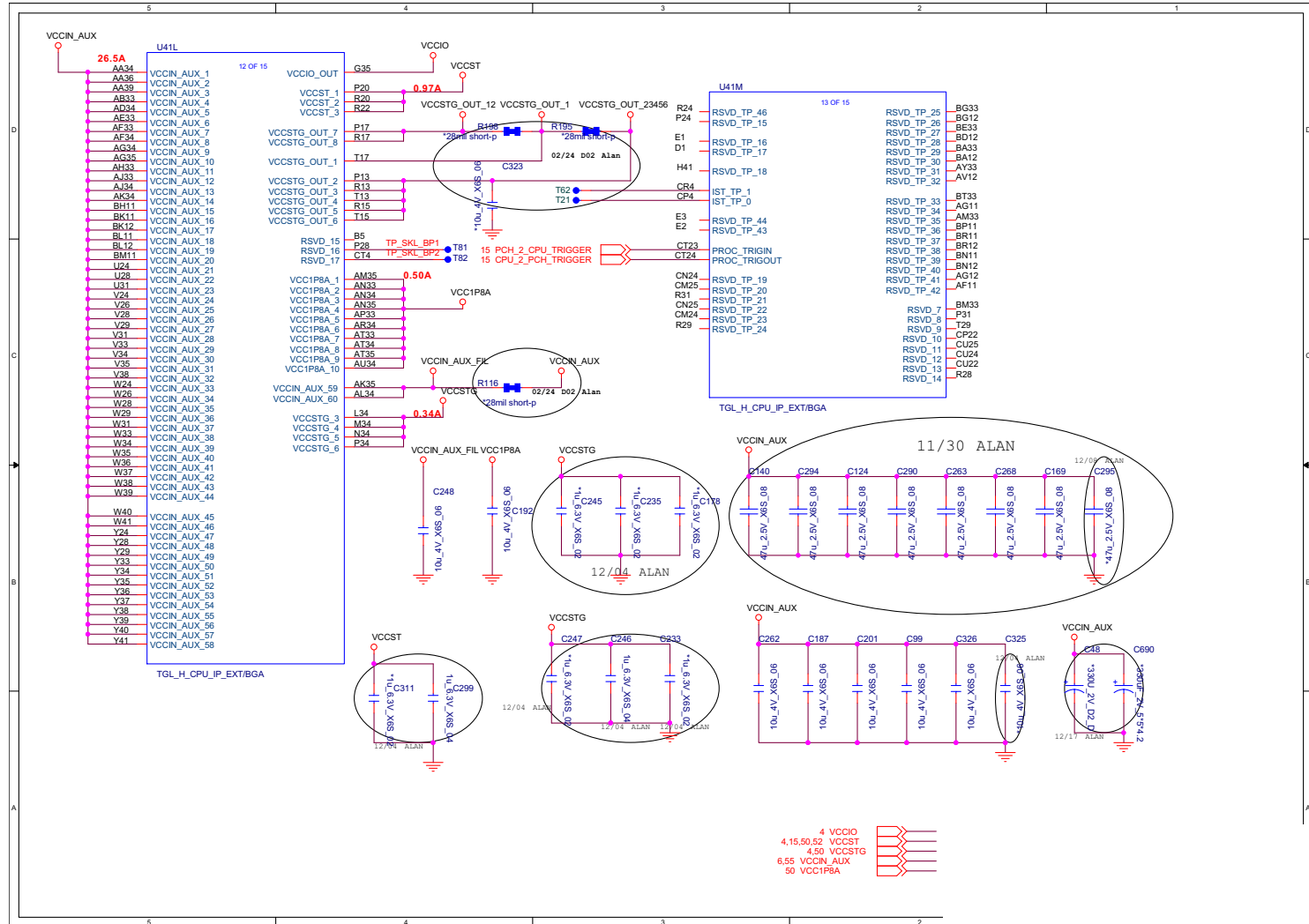

Processor 7/8

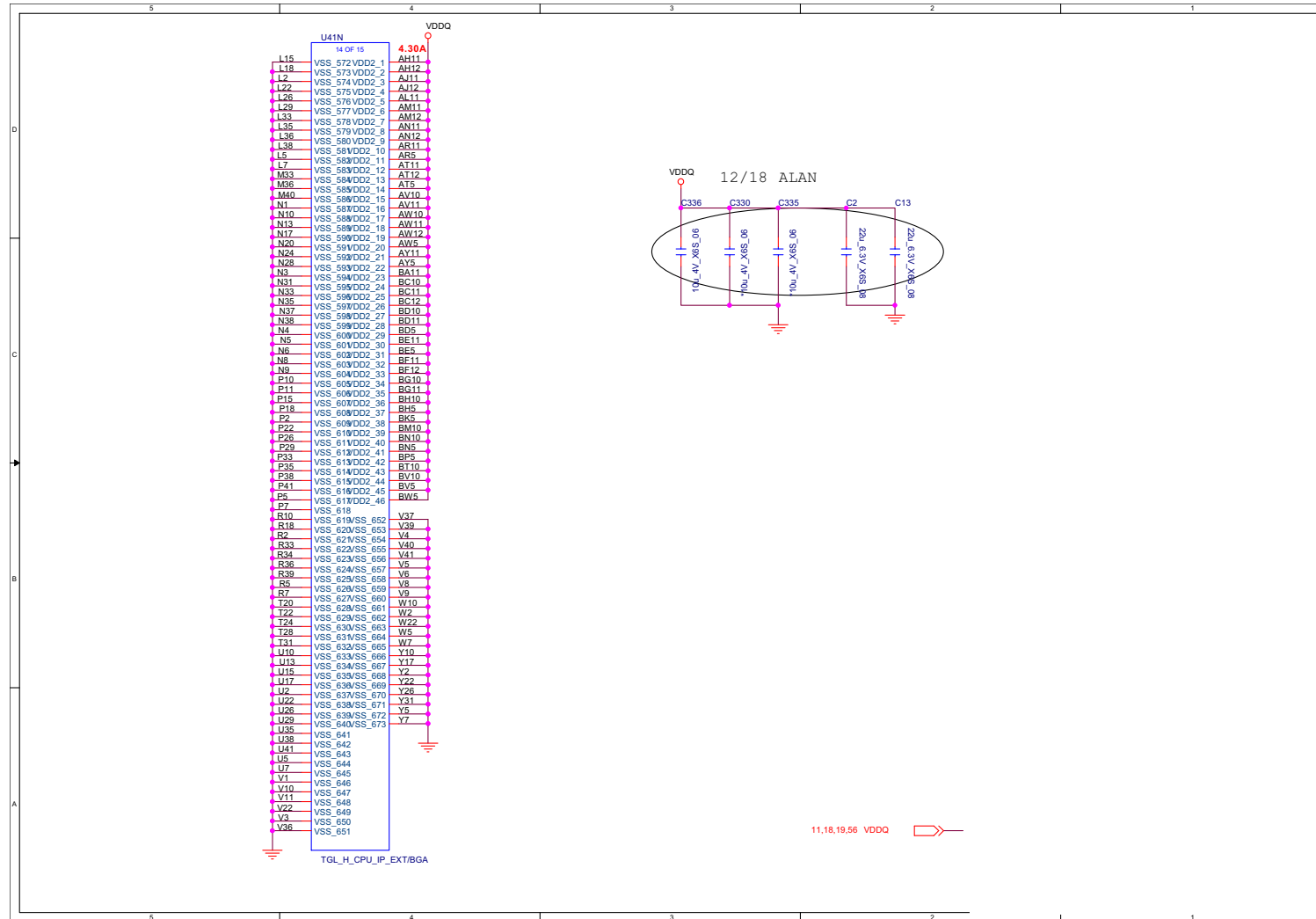

Sheet 8 of 70
Processor 7/8

B.Schematic Diagrams

Processor 8/8

Sheet 9 of 70
Processor 8/8

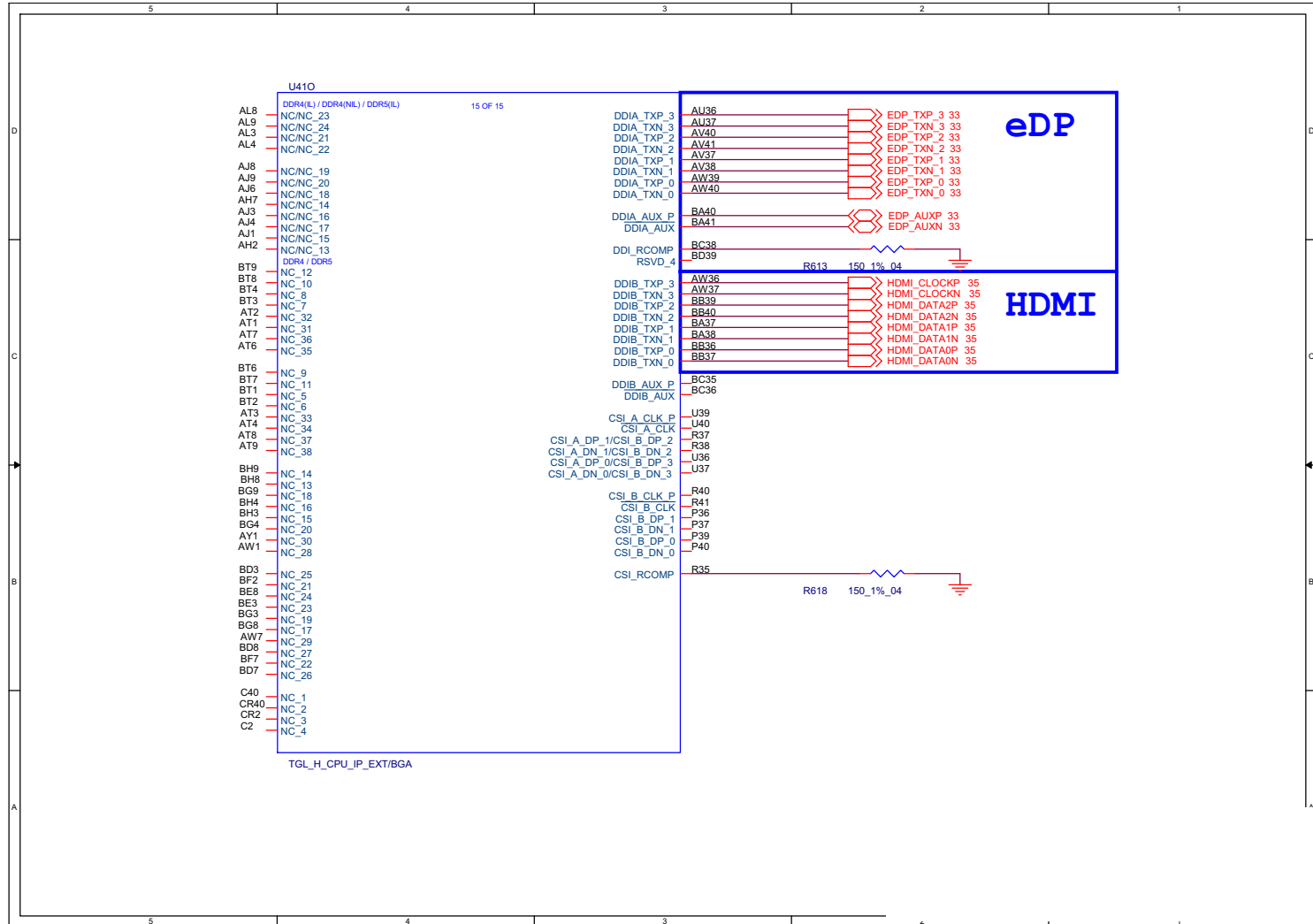

PCH 1/8

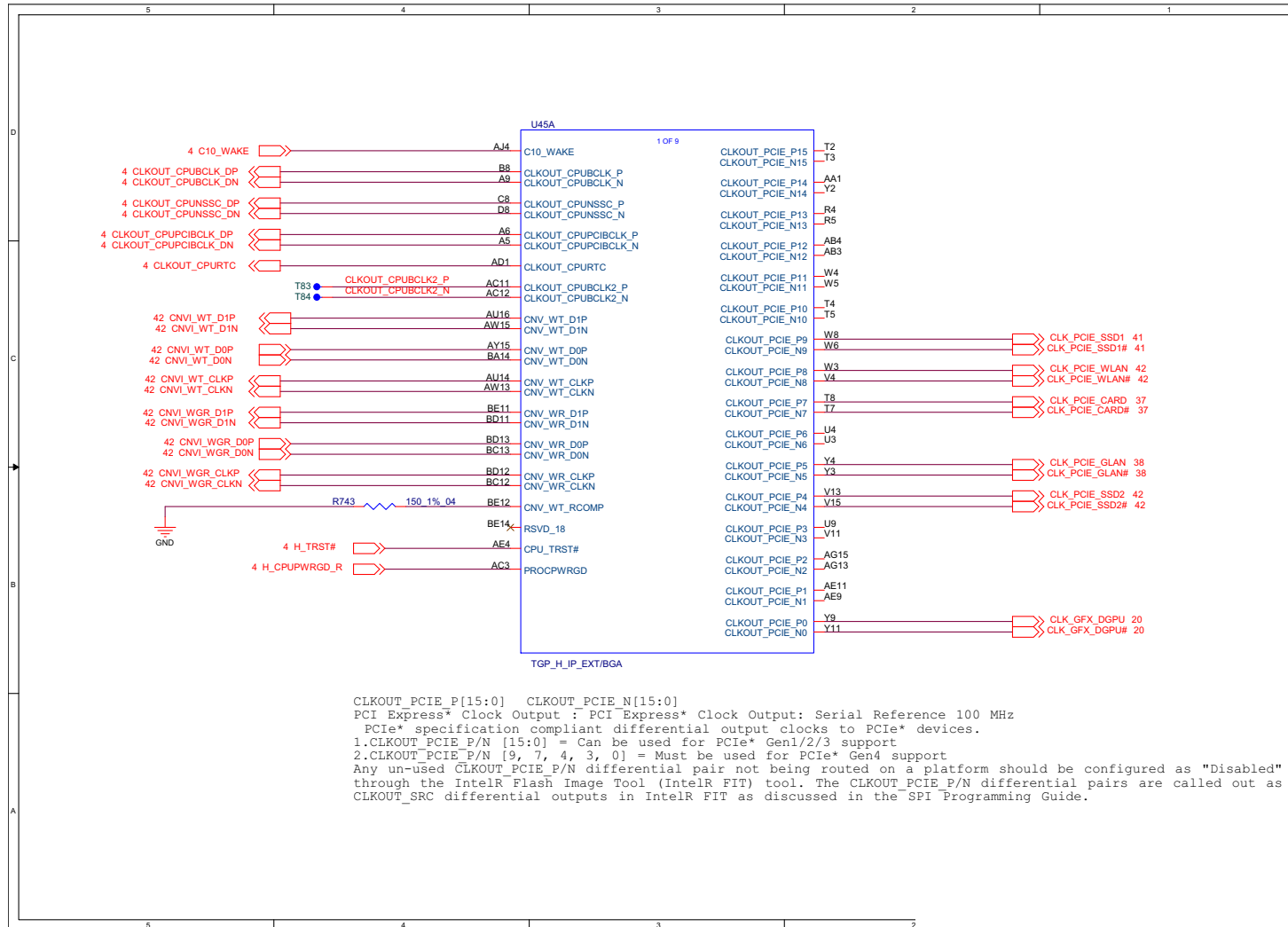

Sheet 10 of 70
PCH 1/8

PCH 2/8

Sheet 11 of 70
PCH 2/8

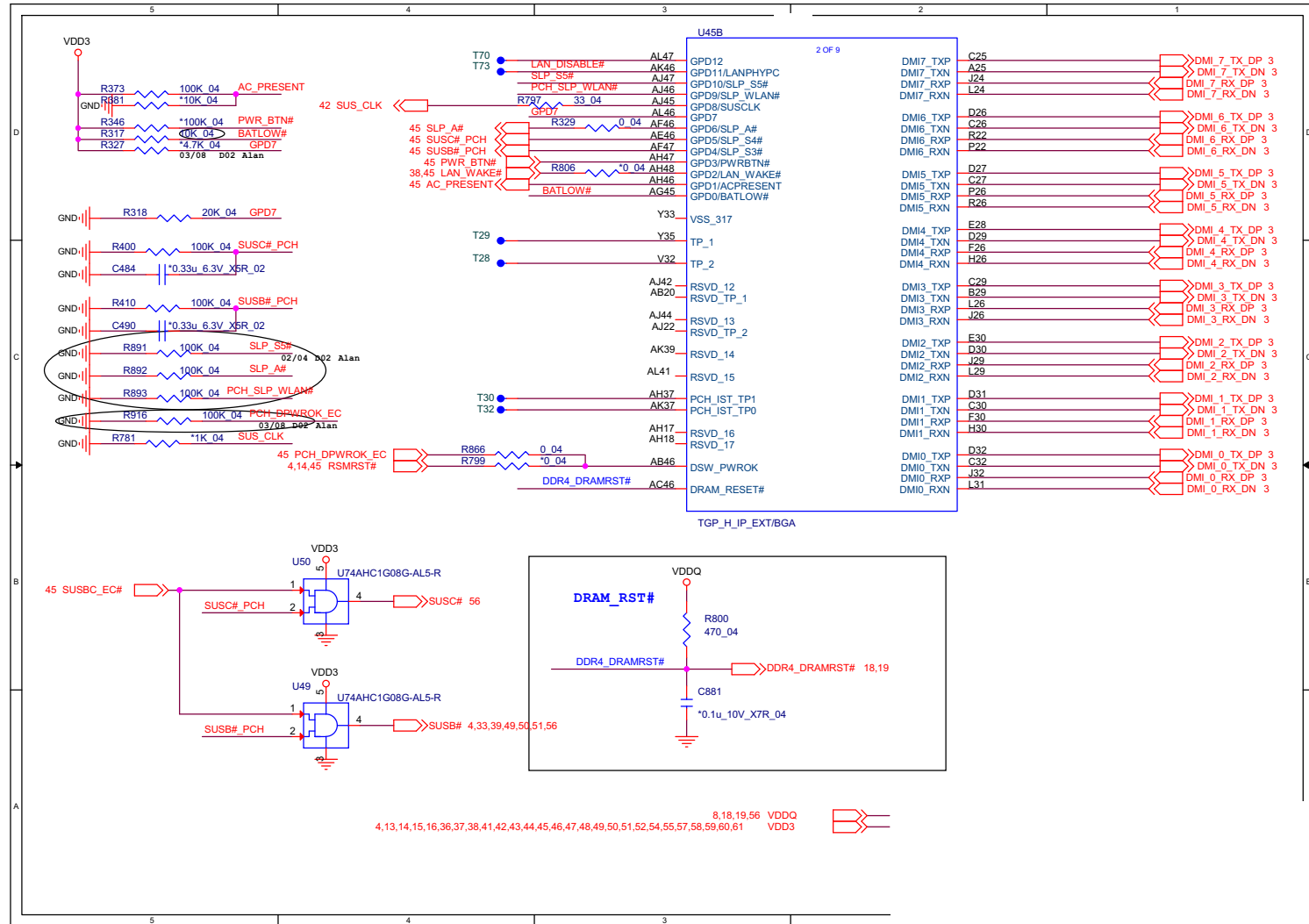

PCH 3/8

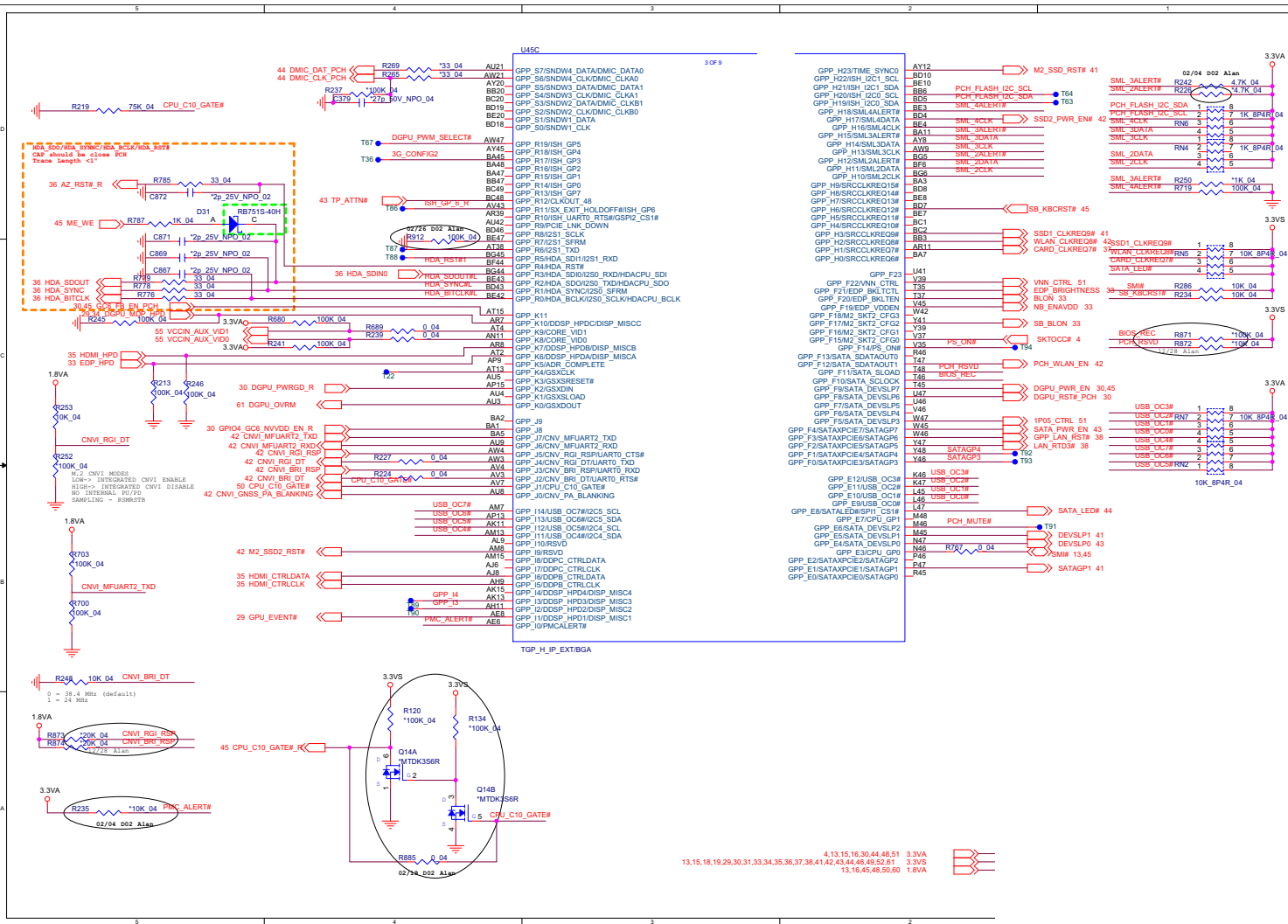

Sheet 12 of 70
PCH 3/8

B.Schematic Diagrams

PCH 4/8

Sheet 13 of 70
PCH 4/8

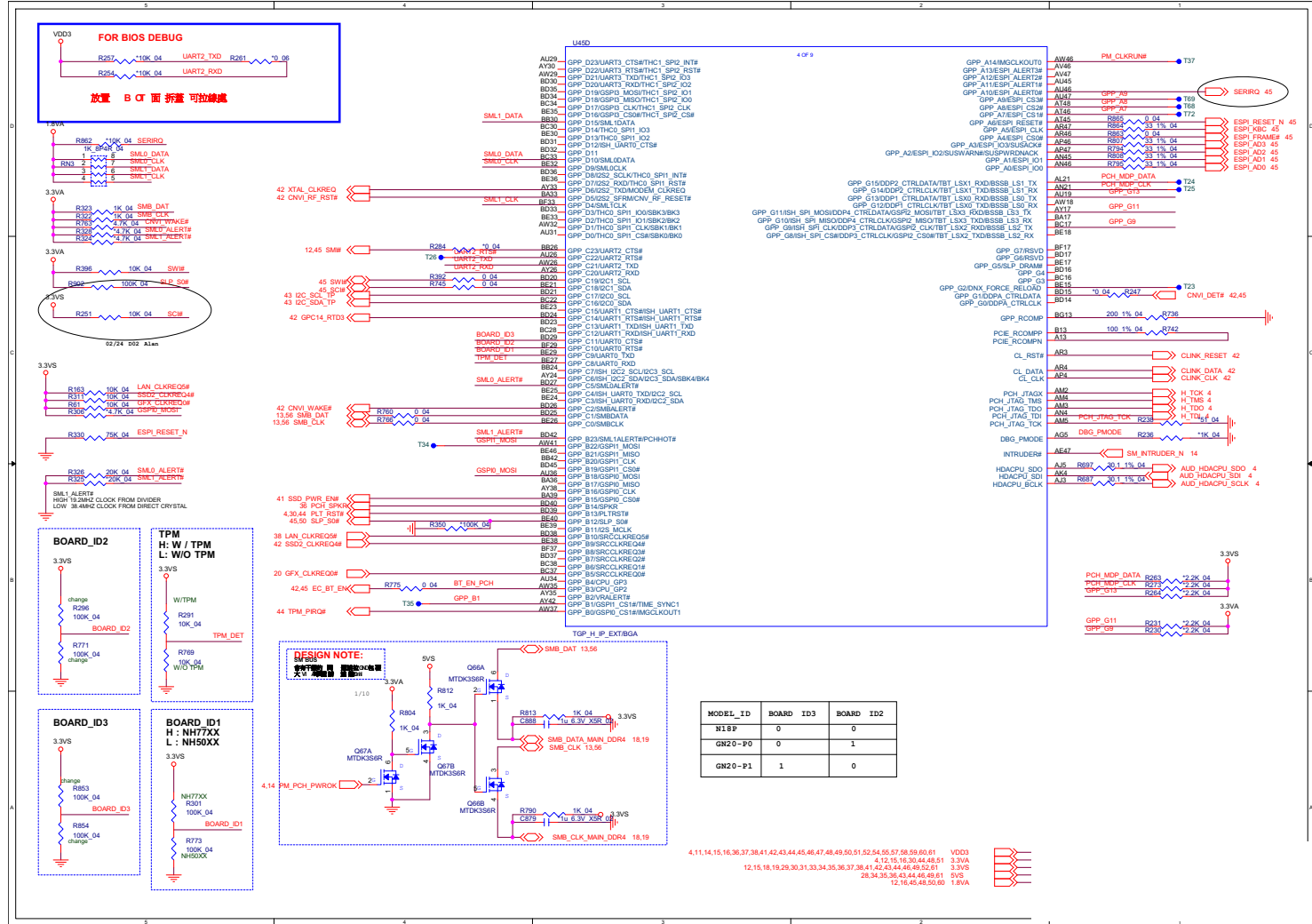

PCH 5/8

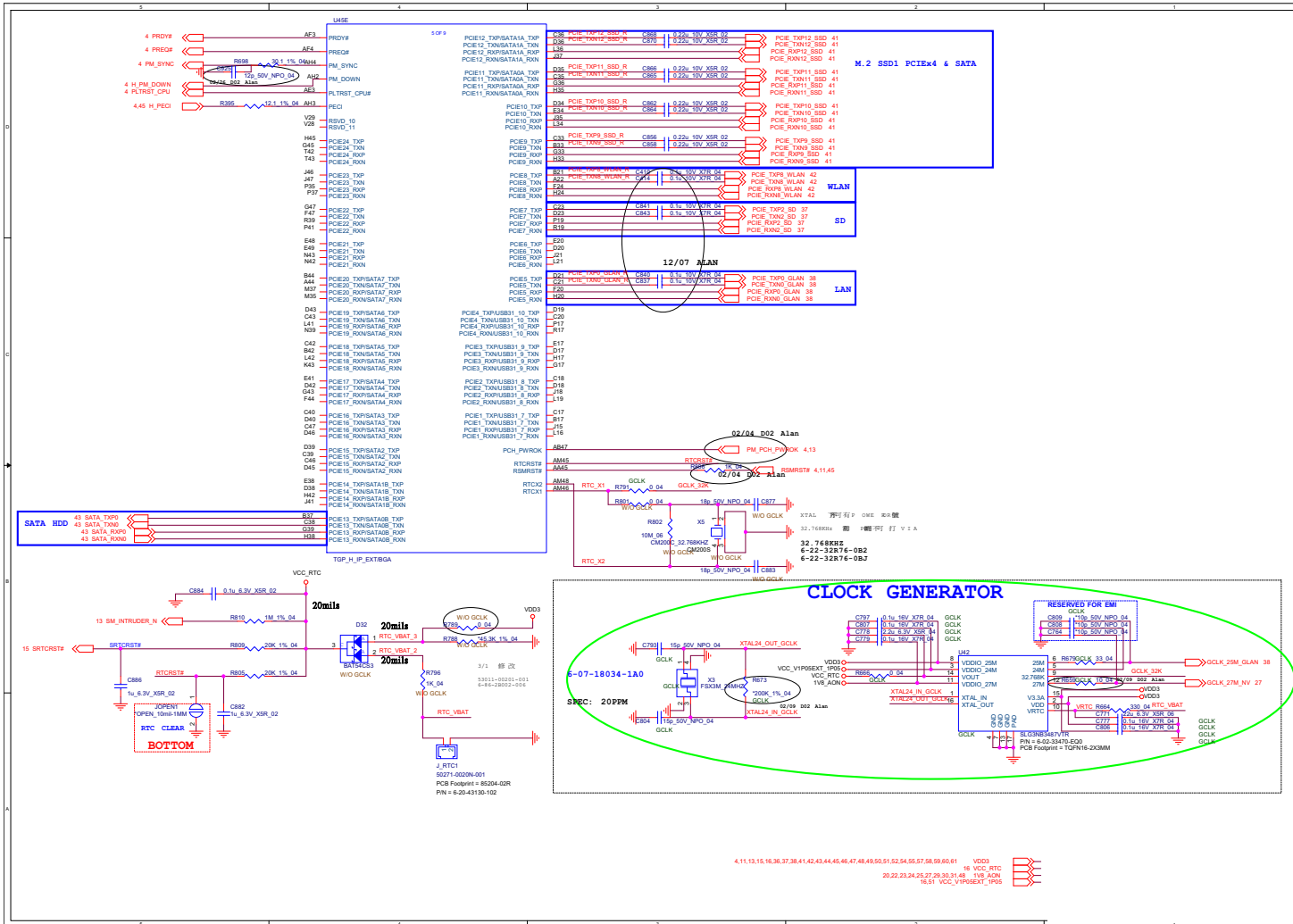

Sheet 14 of 70
PCH 5/8

B.Schematic Diagrams

PCH 7/8

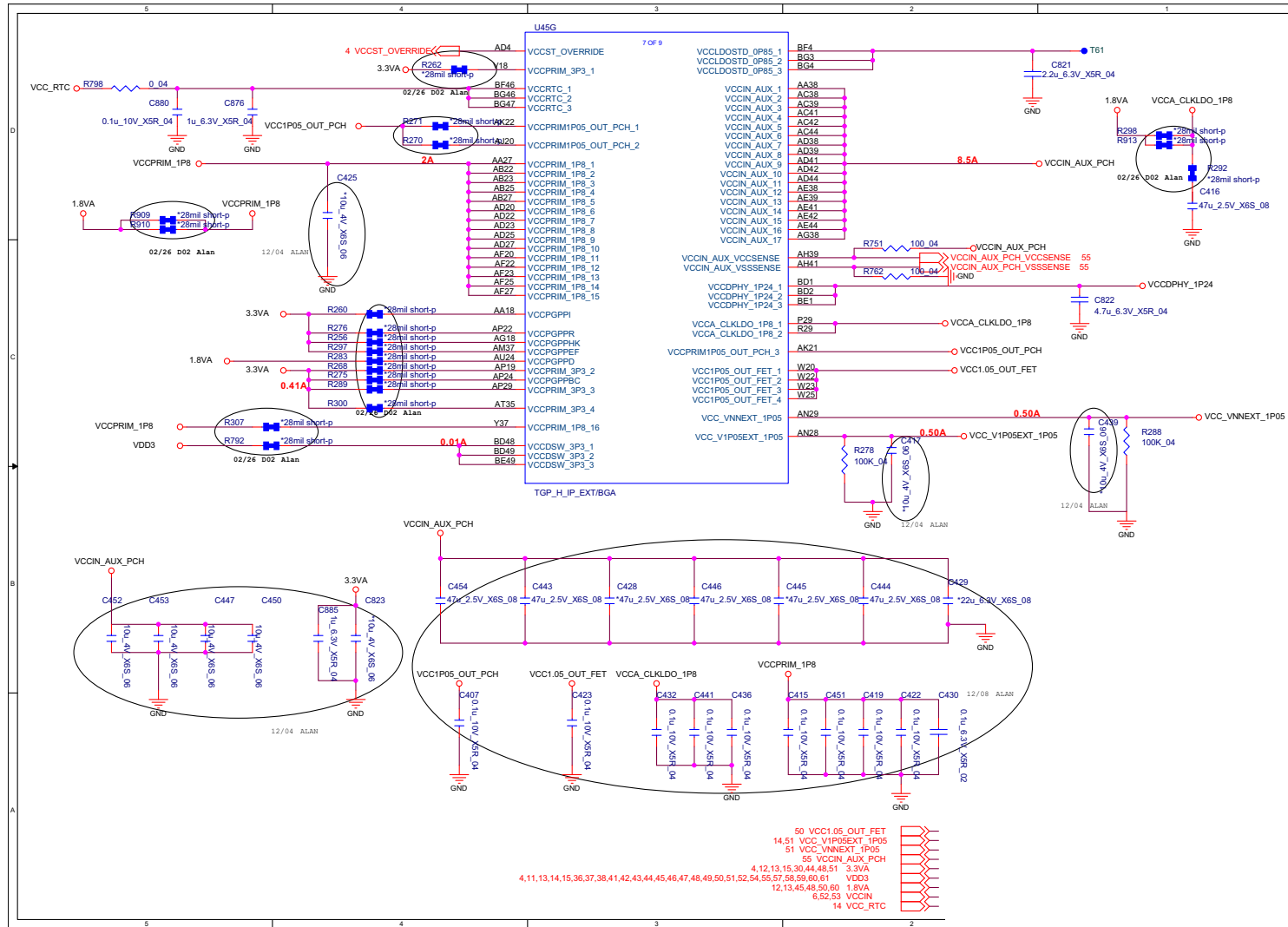

Sheet 16 of 70
PCH 7/8

B. Schematic Diagrams

PCH 8/8

Sheet 17 of 70
PCH 8/8

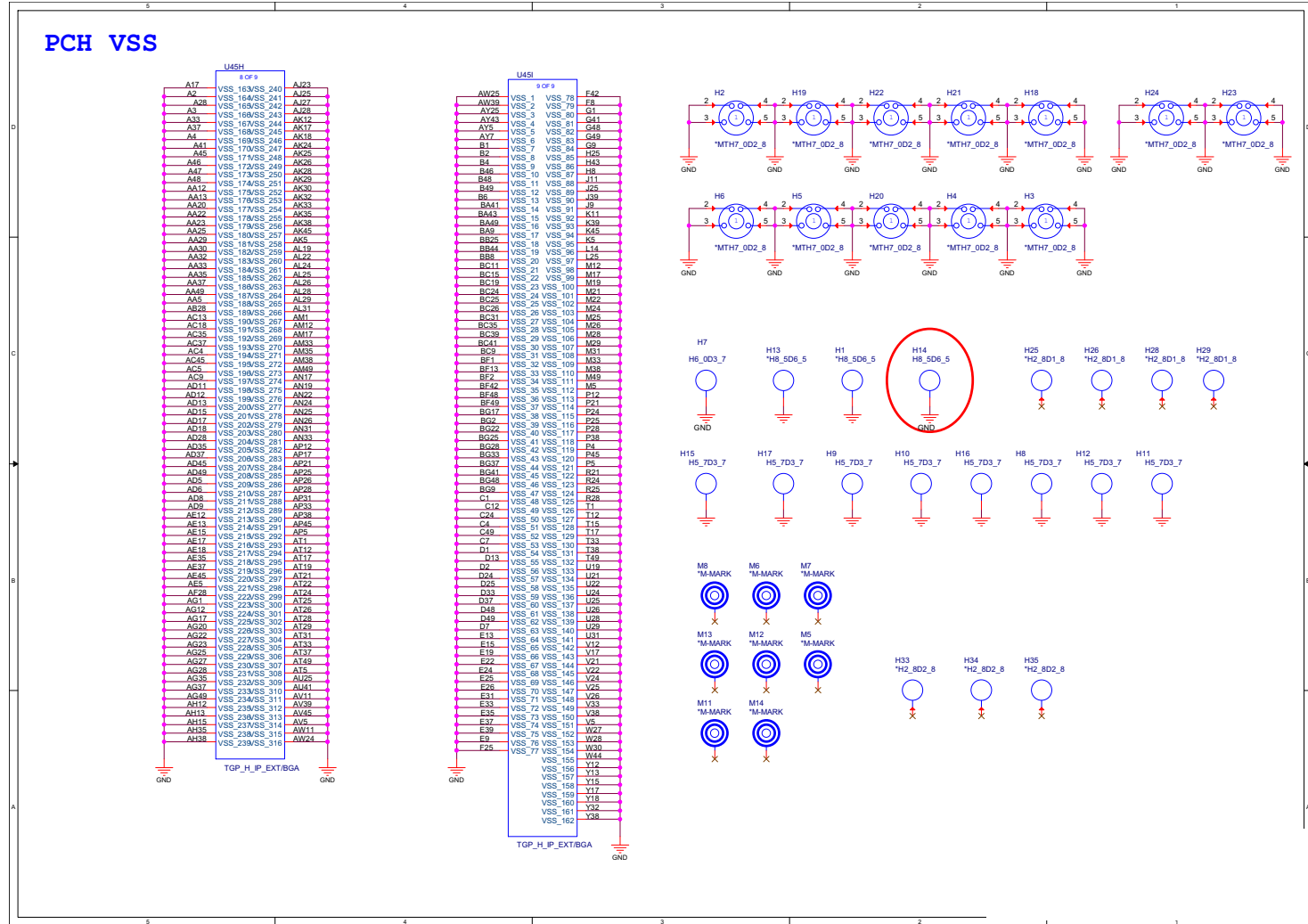

Frame Buffer A

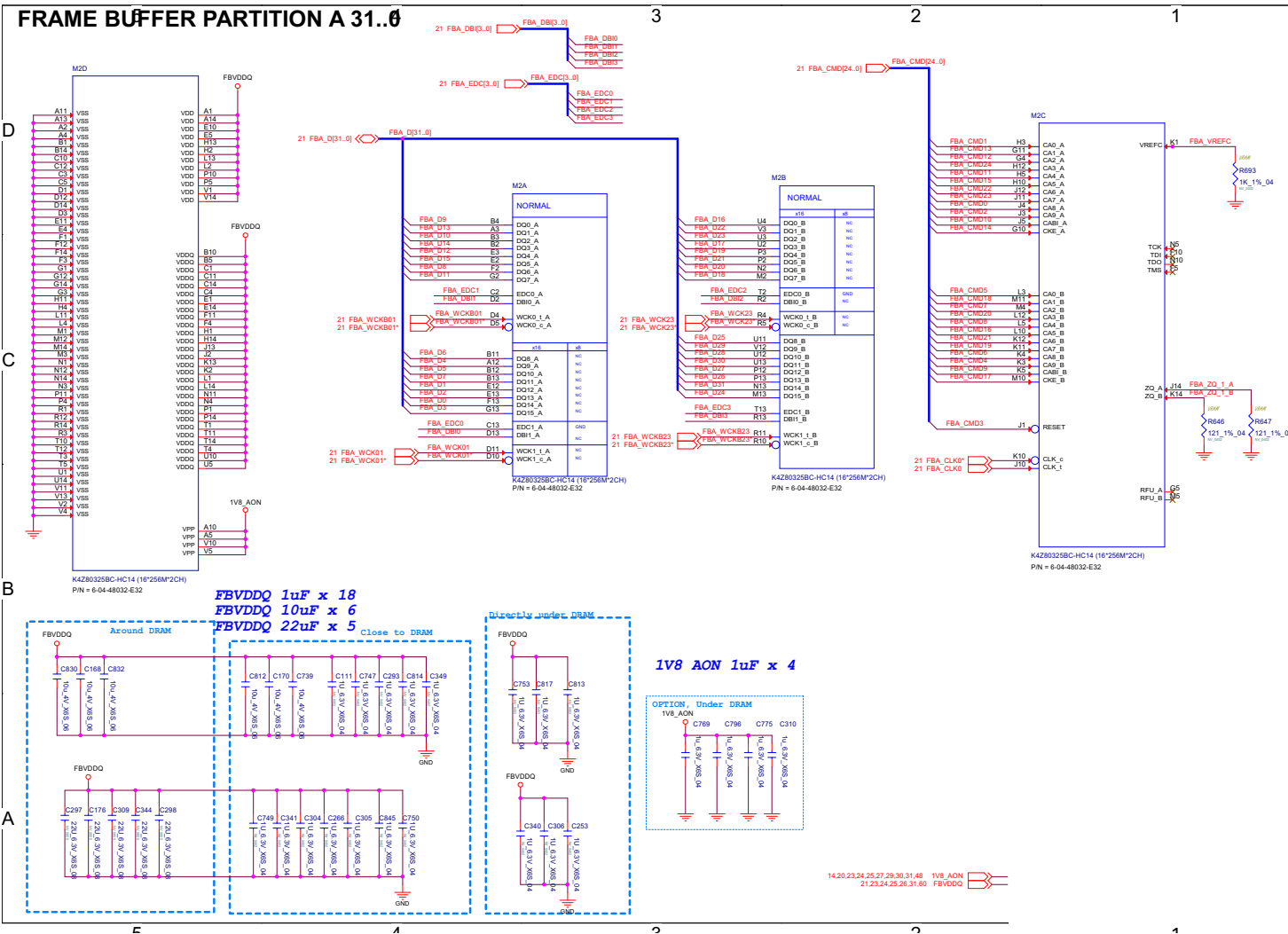

Sheet 22 of 70
Frame Buffer A

B.Schematic Diagrams

Frame Buffer B

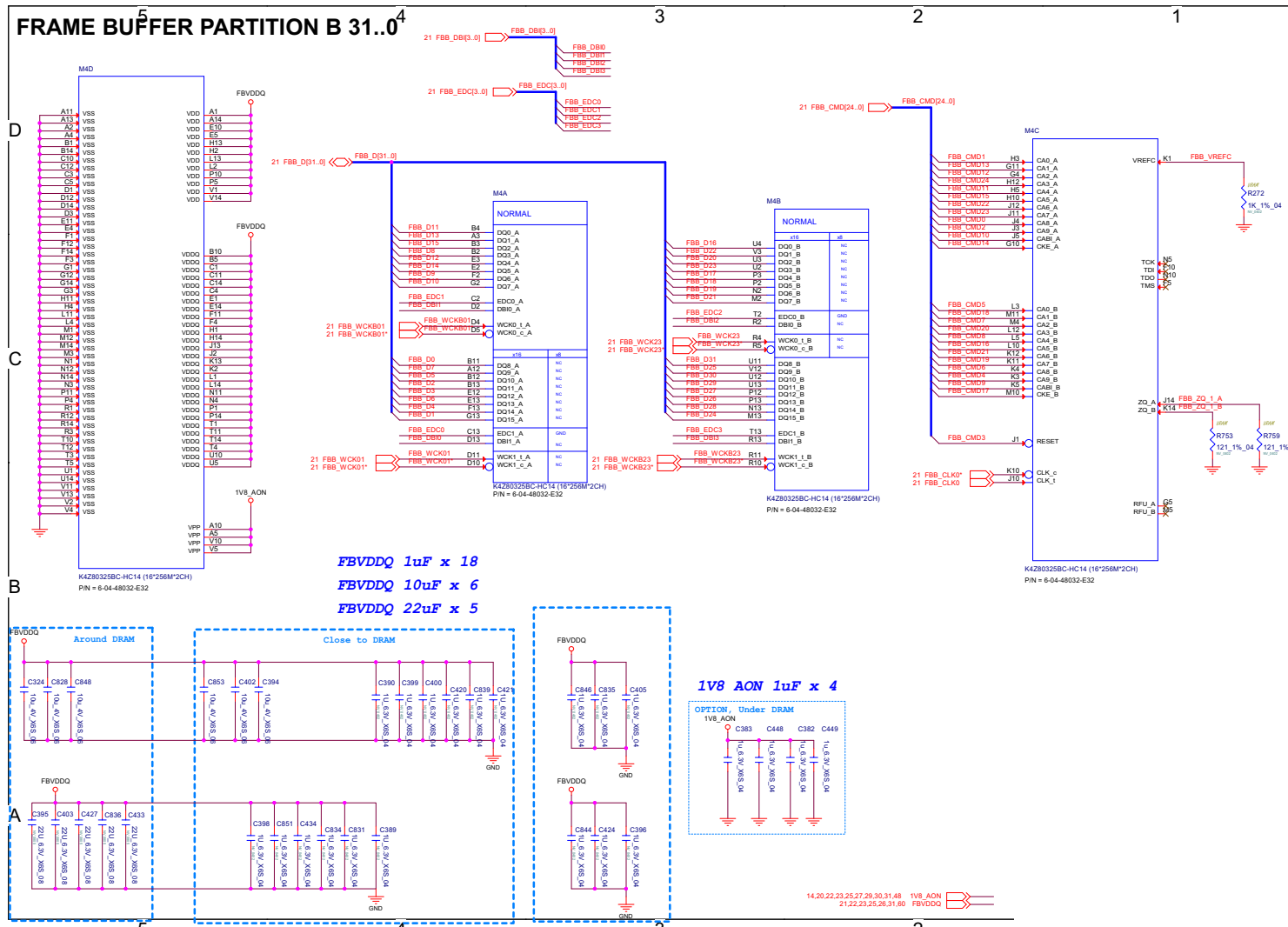

Sheet 24 of 70
Frame Buffer B

B.Schematic Diagrams

Schematic Diagrams

Frame Buffer B

B.Schematic Diagrams

Sheet 25 of 70
Frame Buffer B

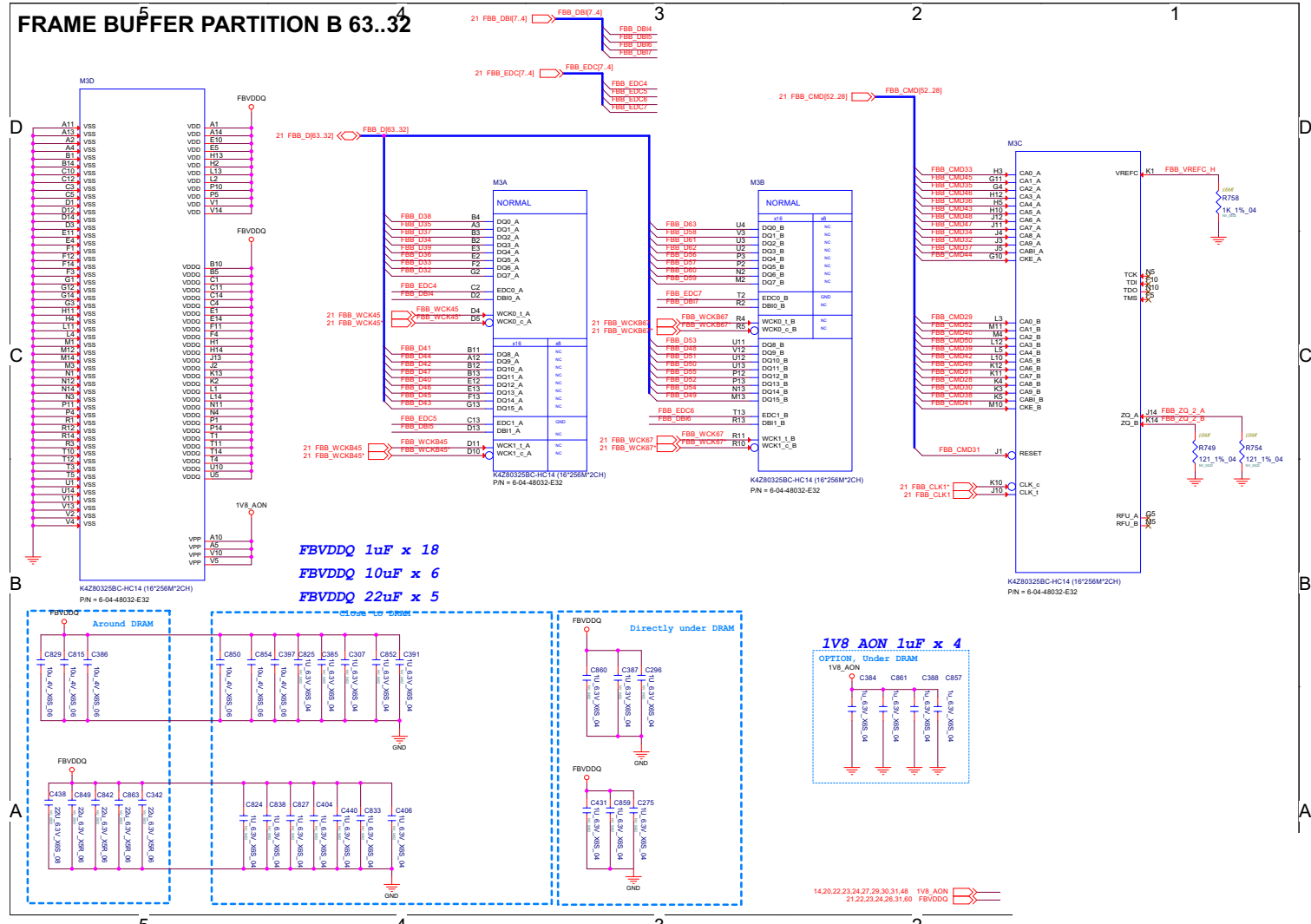

VGA NVVDD Coupling

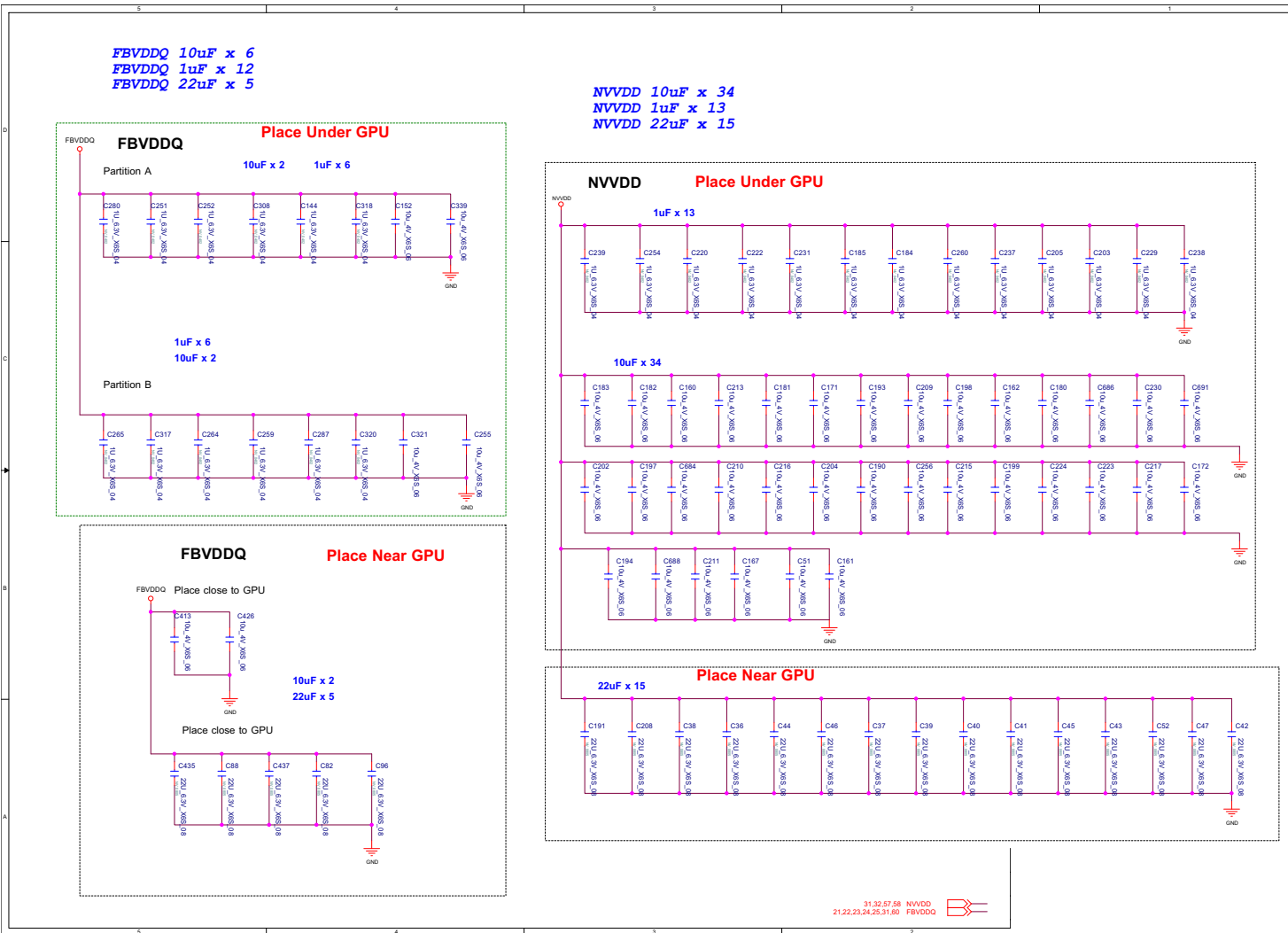

Sheet 26 of 70
 VGA NVVDD
 Coupling

B.Schematic Diagrams

Straps and XTAL

Sheet 27 of 70
Straps and XTAL

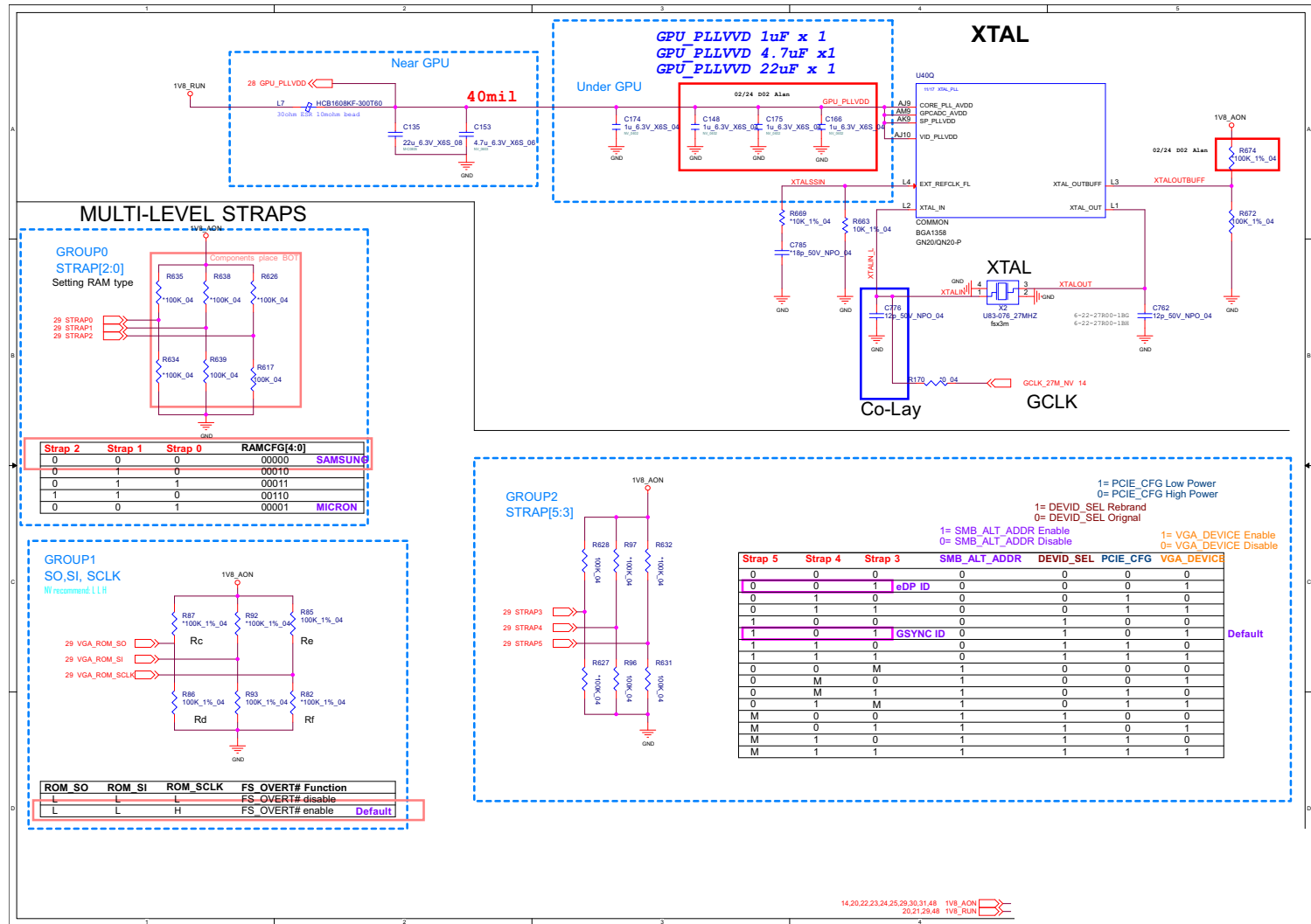

NVIDIA Power Sequence

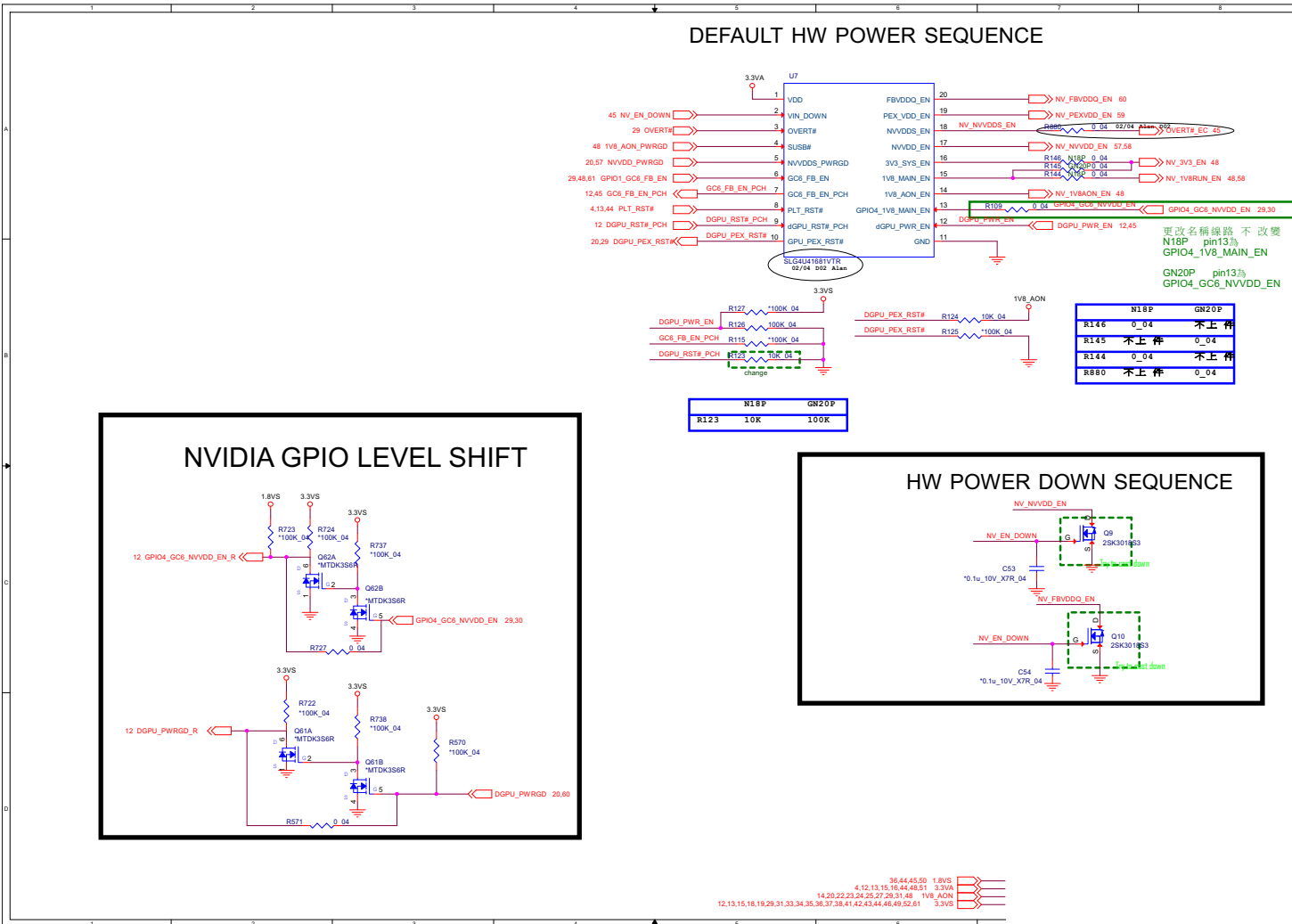

Sheet 30 of 70
NVIDIA Power Sequence

GPU NVVDD, FBVDDQ

Sheet 31 of 70
GPU NVVDD,
FBVDDQ

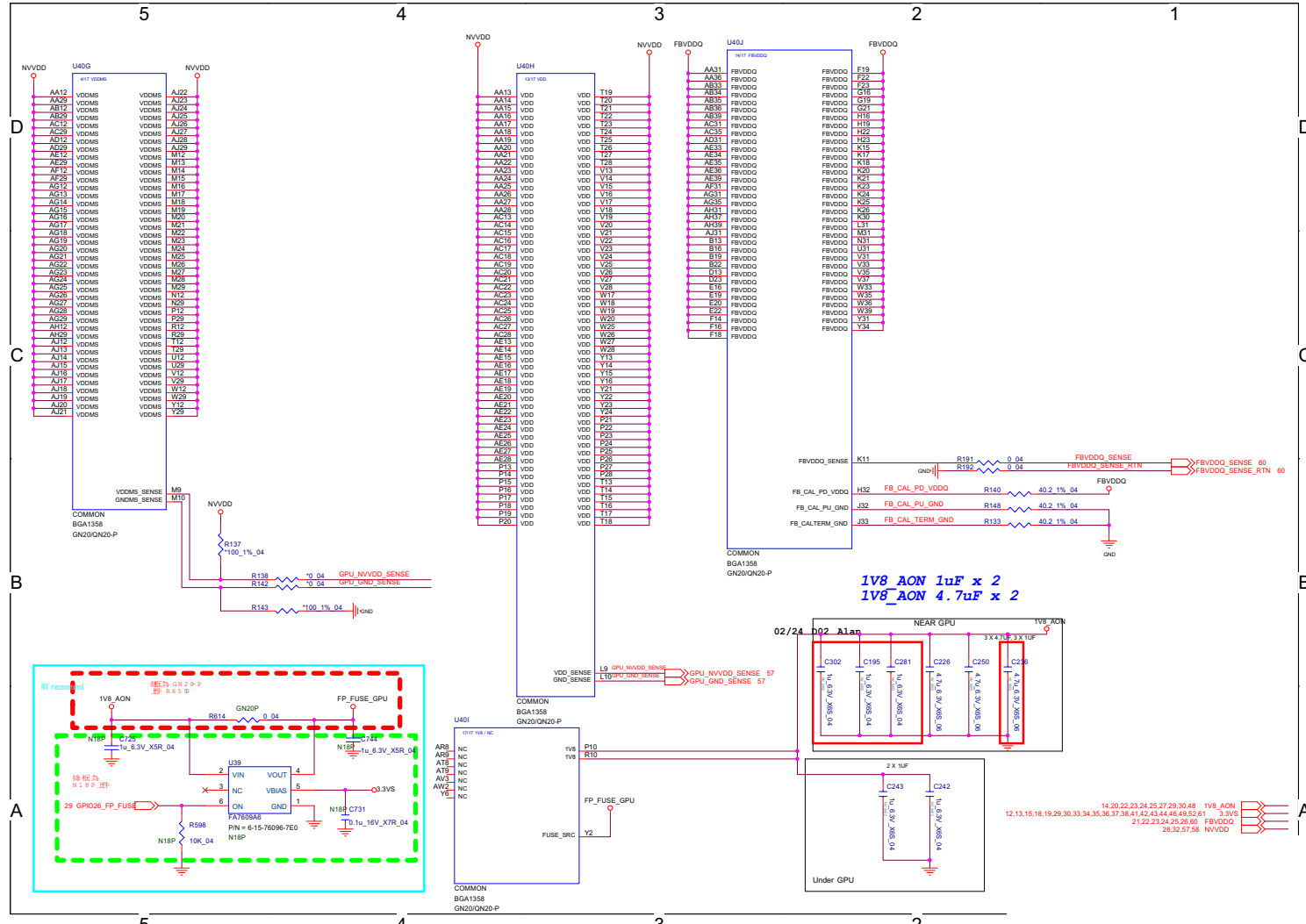

GPU GND

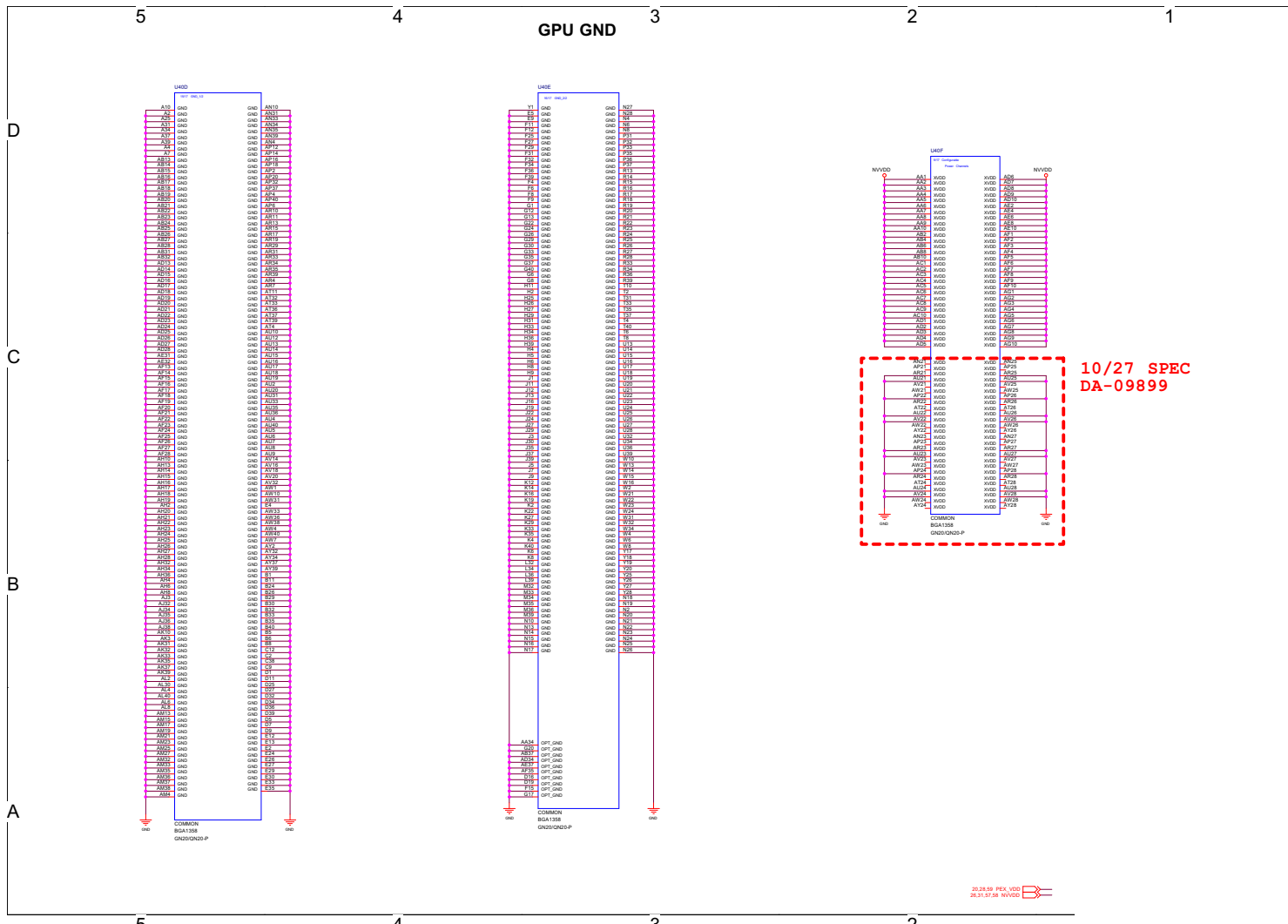

Sheet 32 of 70
GPU GND

B. Schematic Diagrams

Schematic Diagrams

Panel

B.Schematic Diagrams

Sheet 33 of 70
Panel

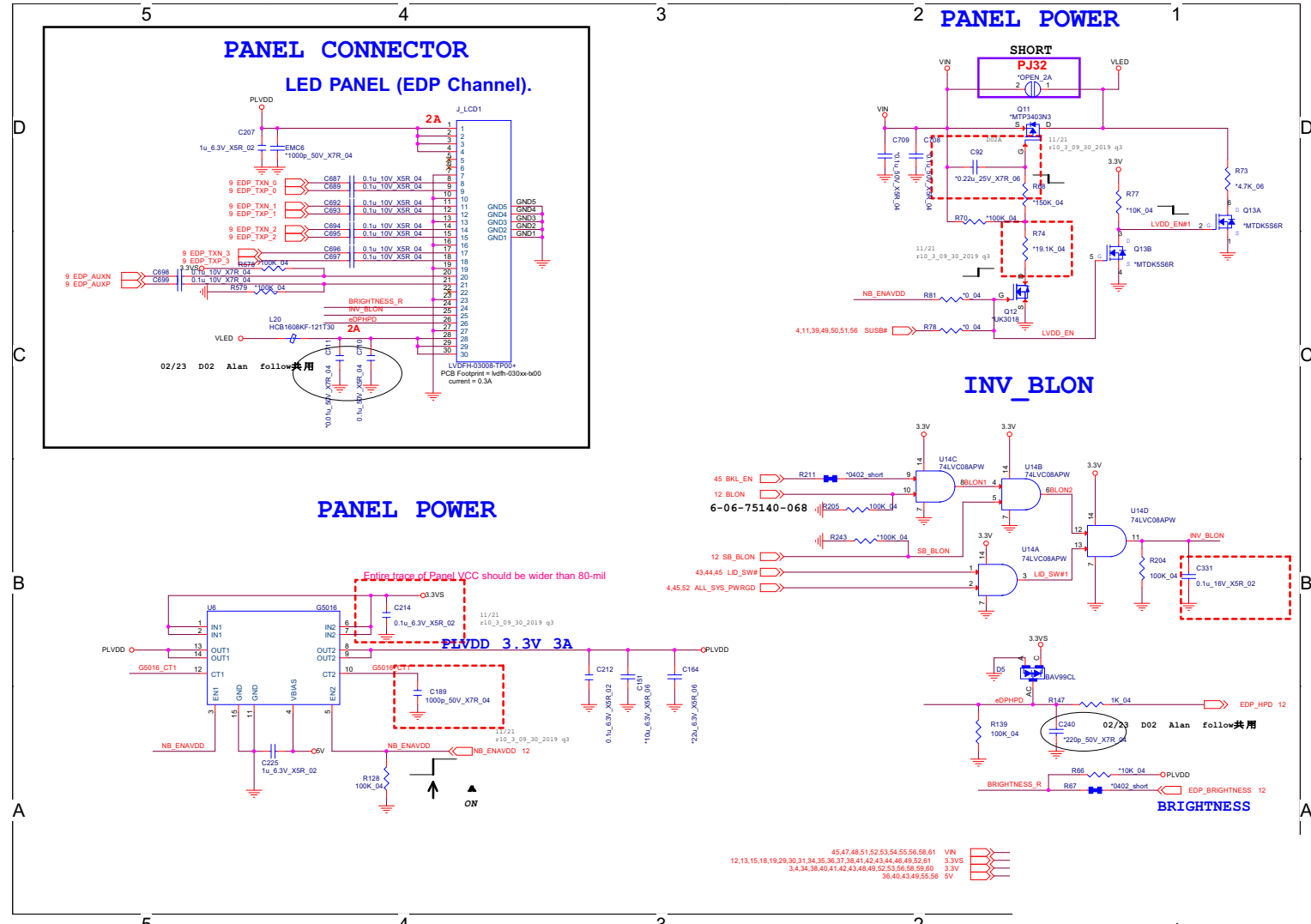

Audio Codec

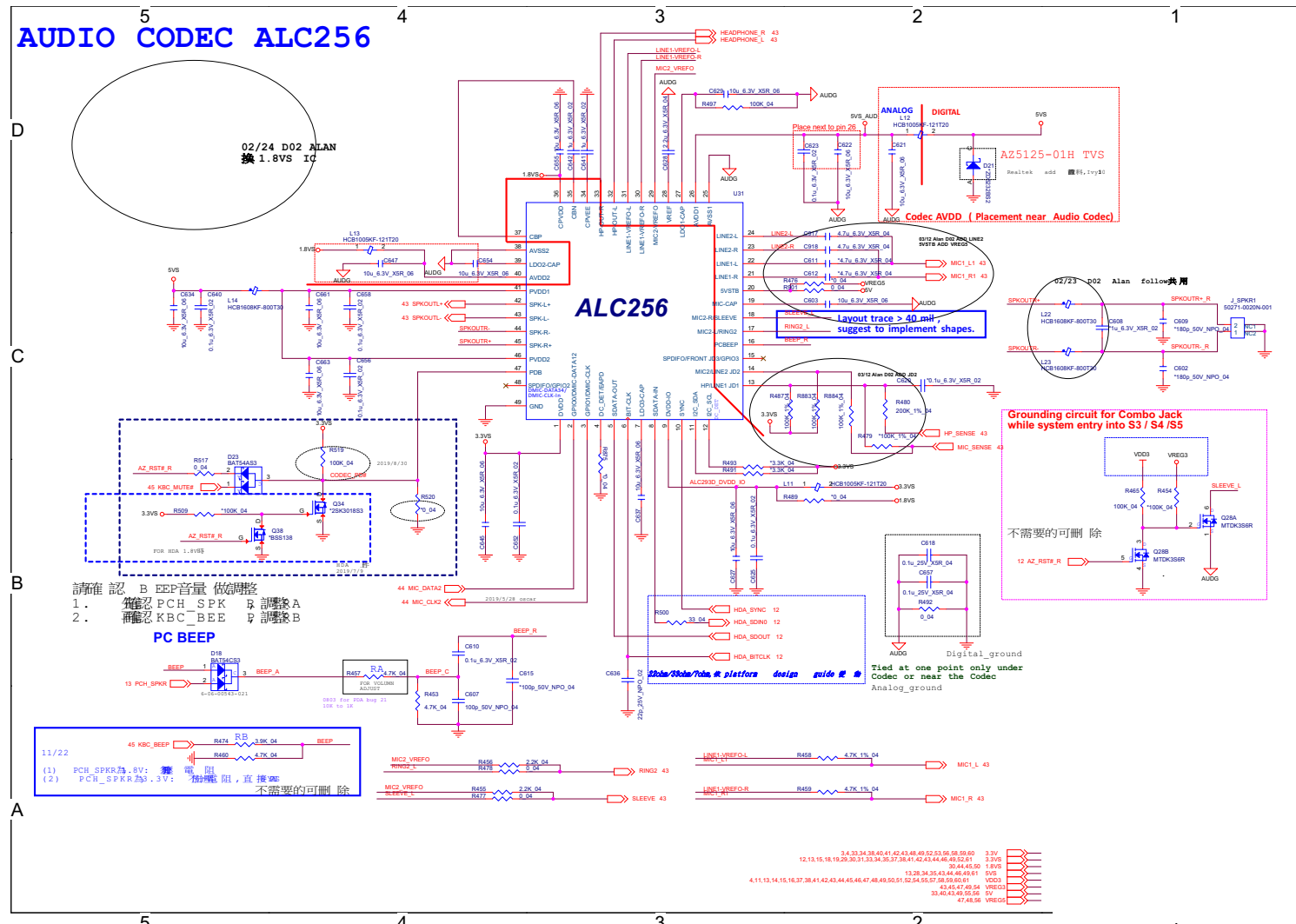

Sheet 36 of 70
Audio Codec

Card Reader & LAN_RTL5227S

Sheet 37 of 70
Card Reader
LAN_RTS5227S

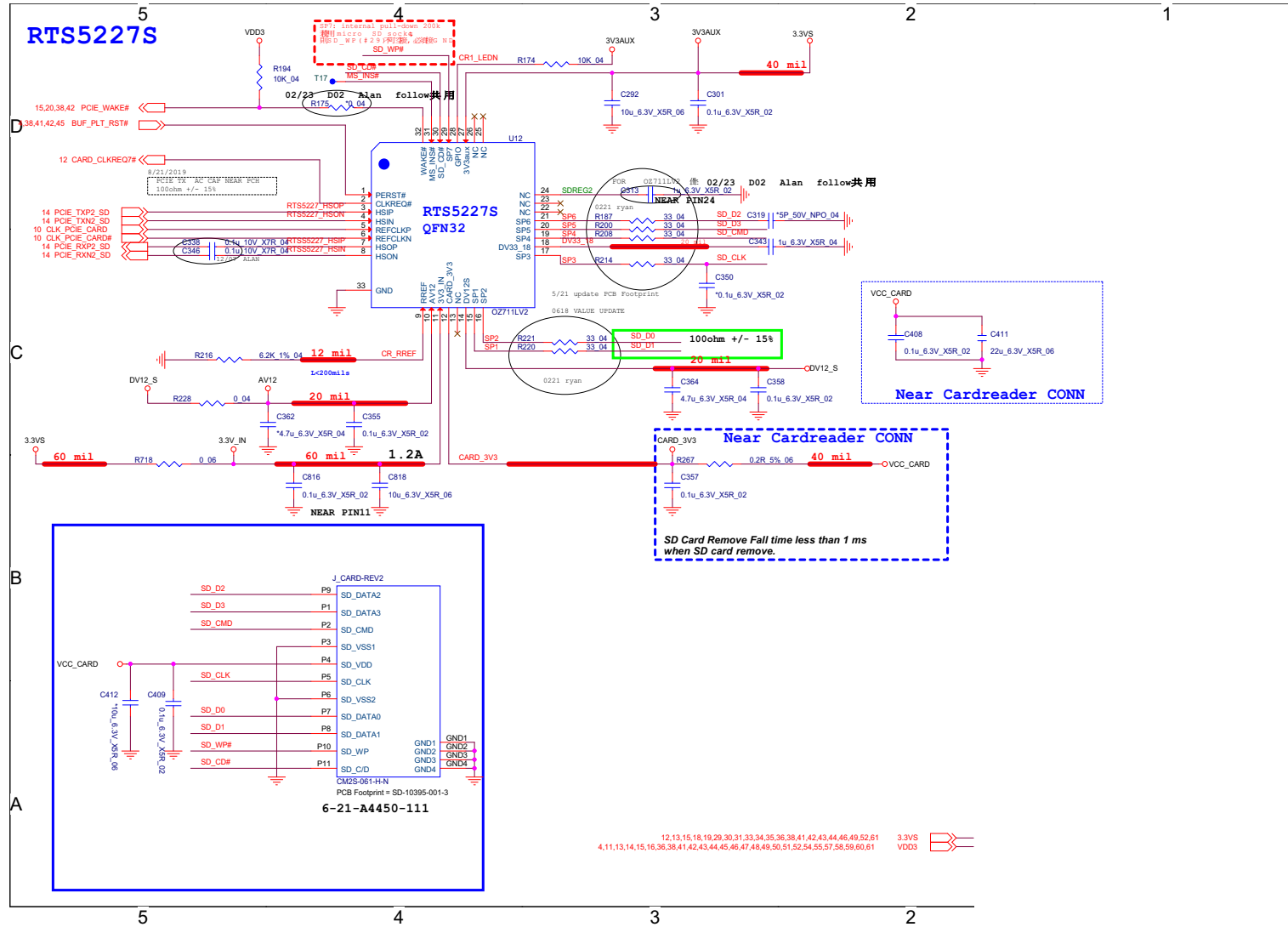

LAN RTL8111H RTD3

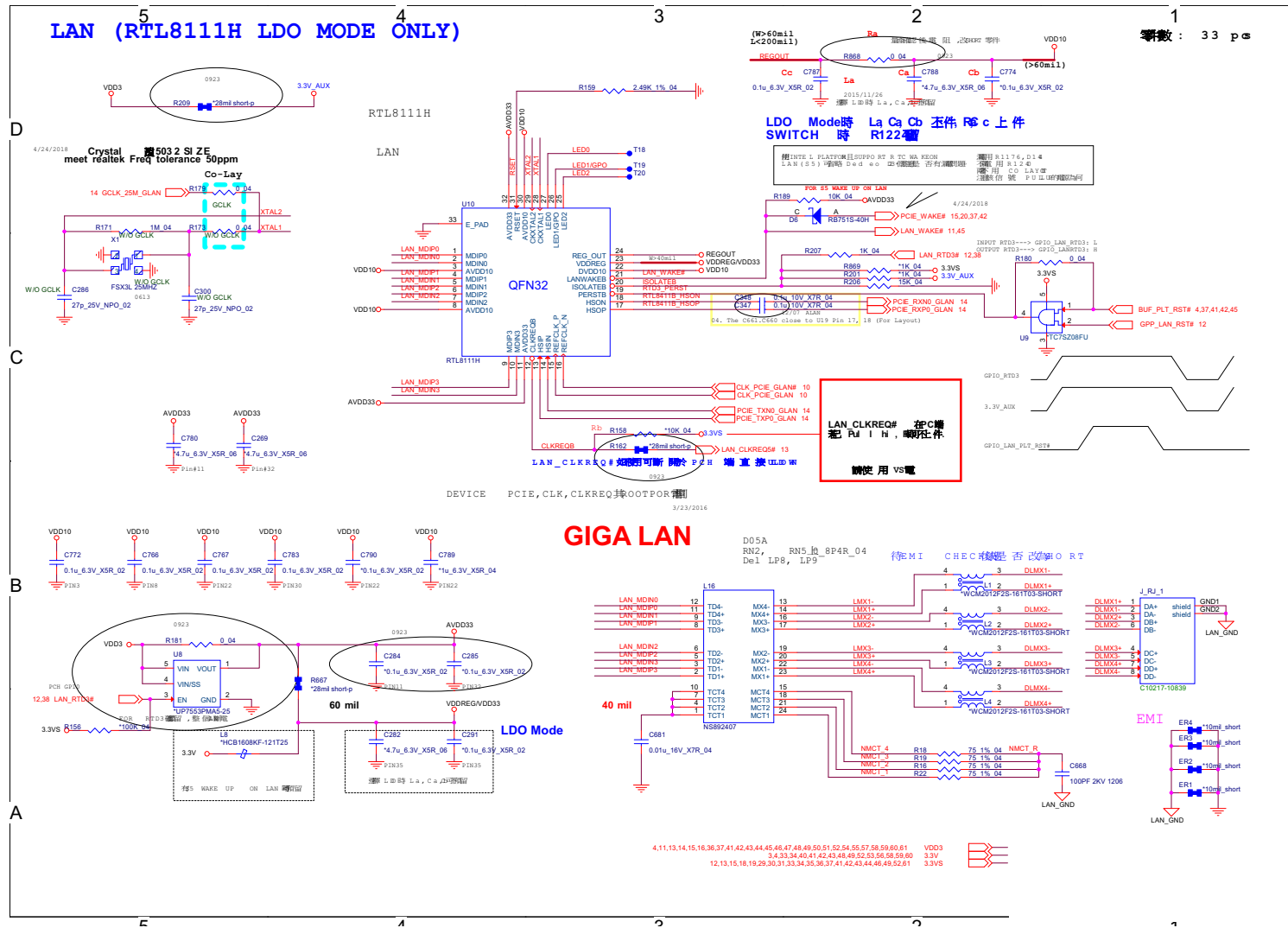

Sheet 38 of 70
LAN RTL8111H
RTD3

B.Schematic Diagrams

USB Type-A

Sheet 39 of 70
USB Type-A

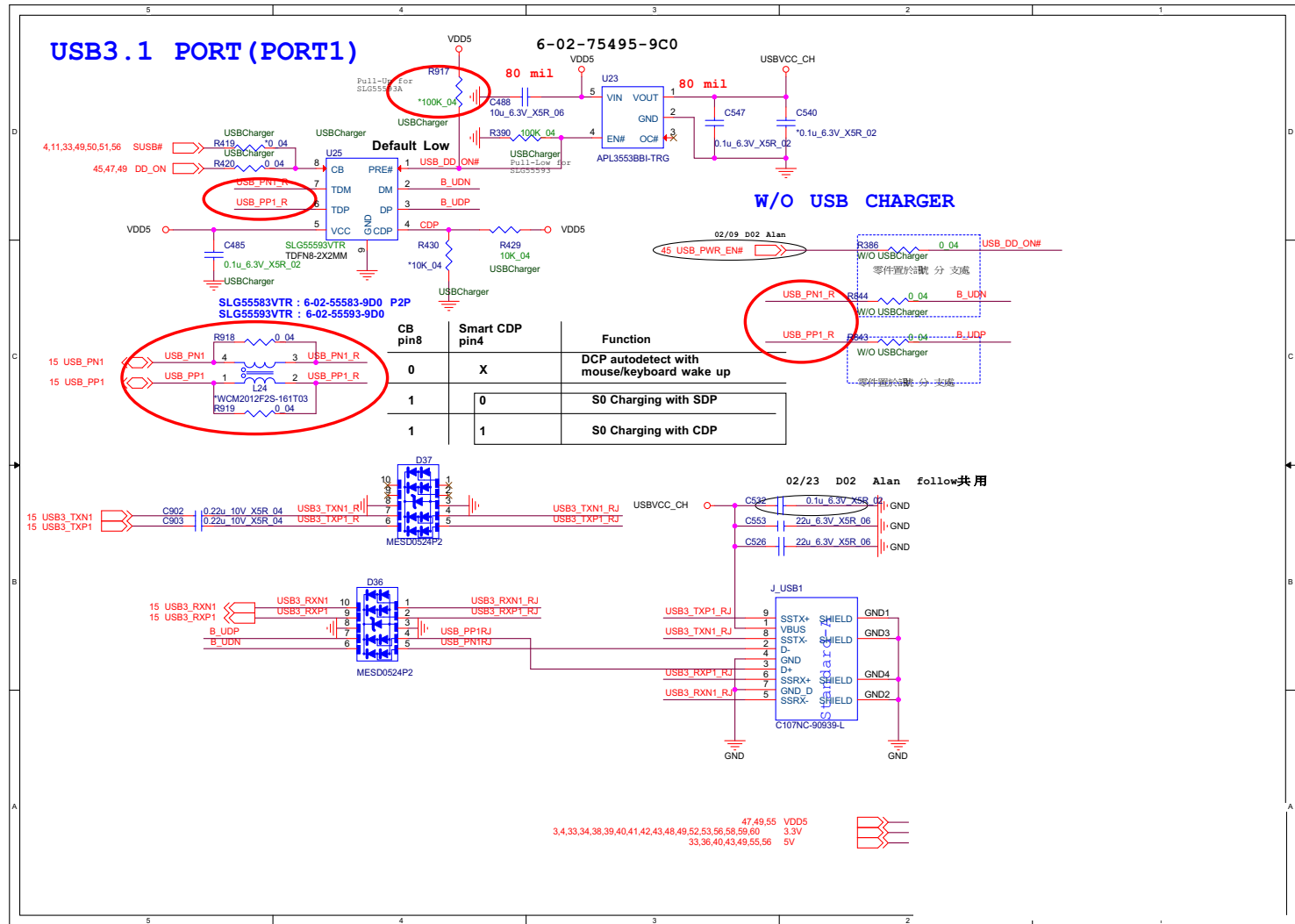

USB Type-C

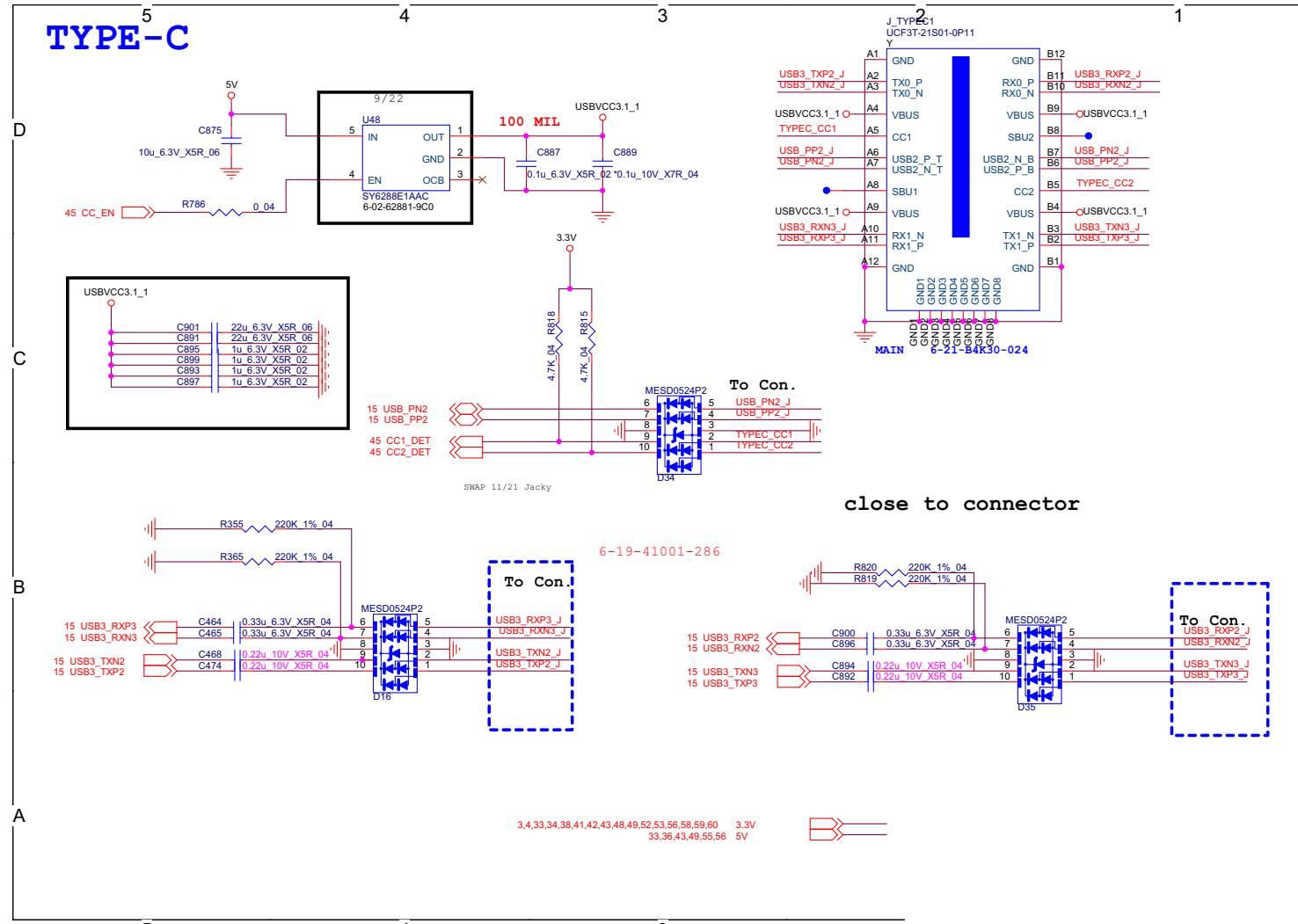

Sheet 40 of 70
USB Type-C

B.Schematic Diagrams

M.2 WLAN+BT, PCIE 4X SSD

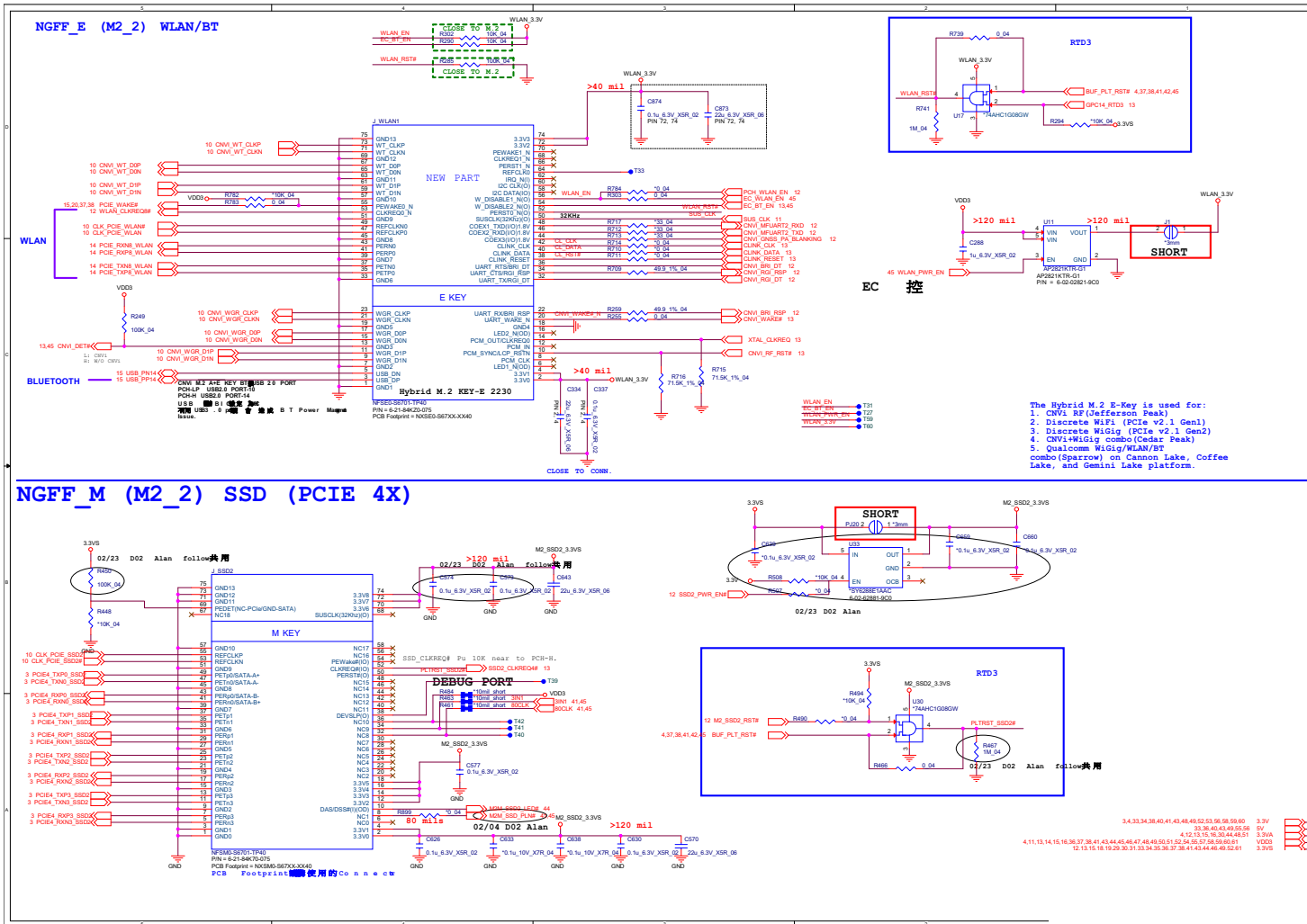

Sheet 42 of 70
M.2 WLAN+BT,
PCIE 4X SSD

B.Schematic Diagrams

LED, CCD, Power SW Bd.

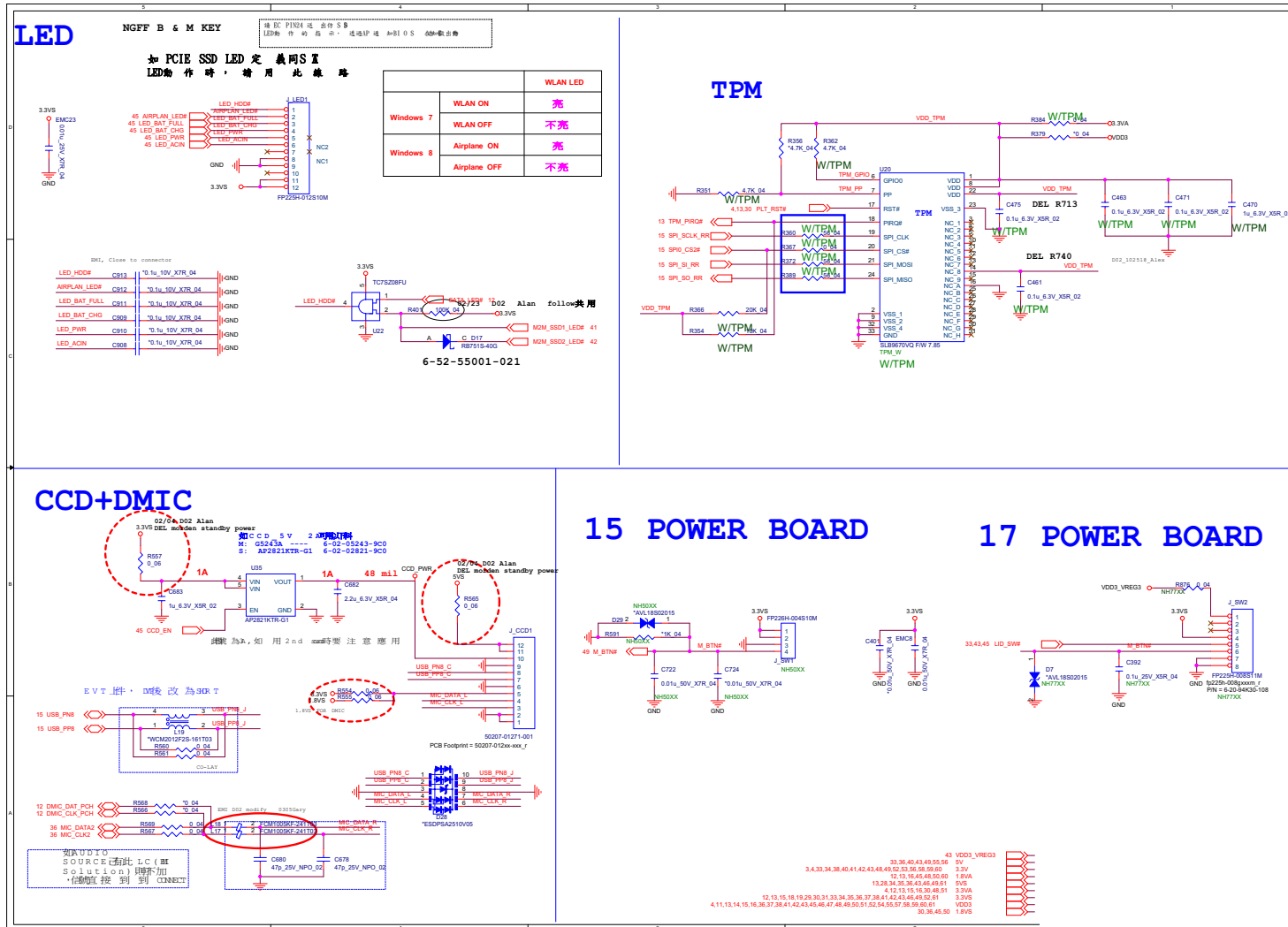

Sheet 44 of 70
LED, CCD, TPower
SW Bd.

B.Schematic Diagrams

KBC-ITE IT5570

B.Schematic Diagrams

Sheet 45 of 70
KBC-ITE IT5570

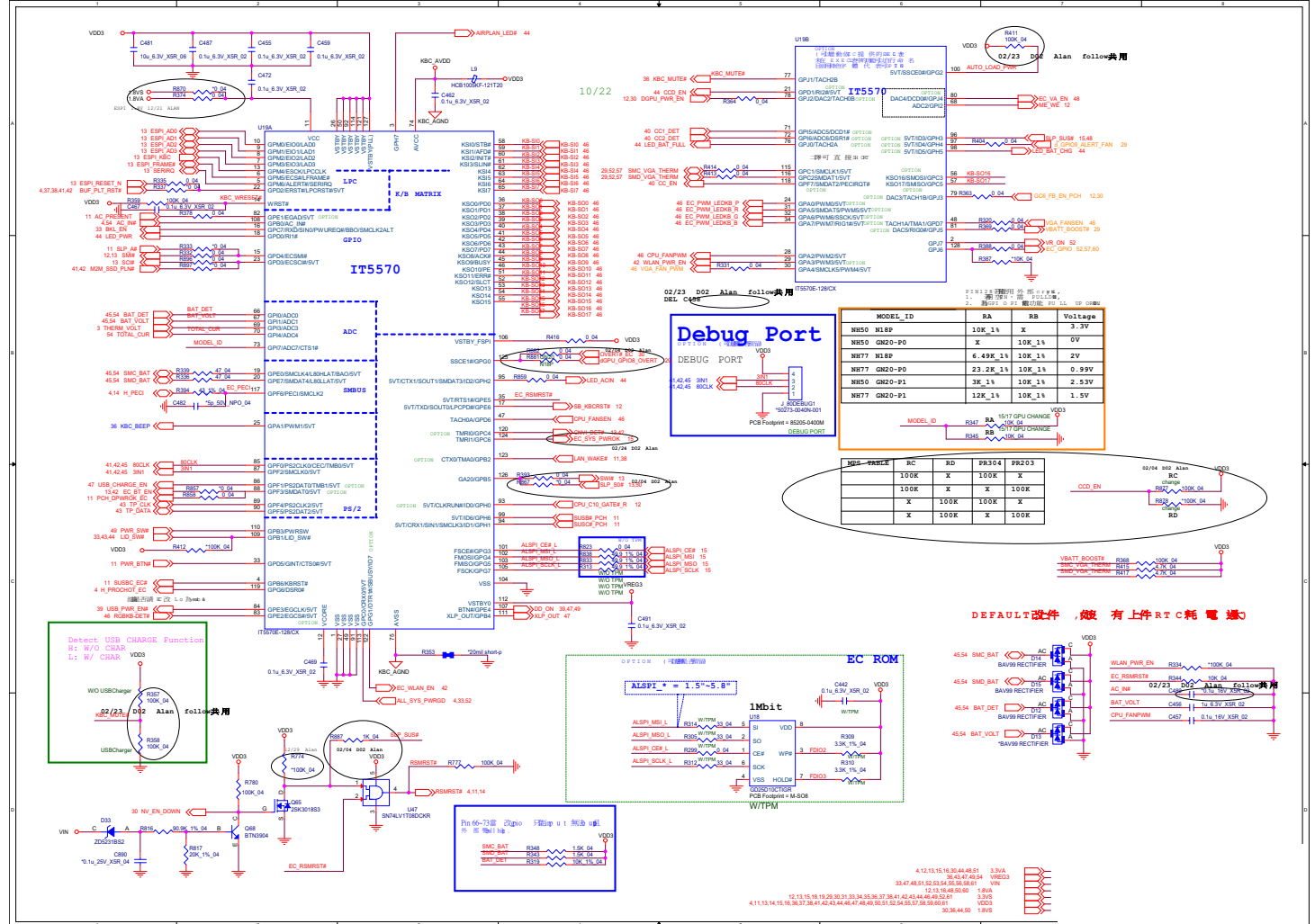

RGB KB, Fan

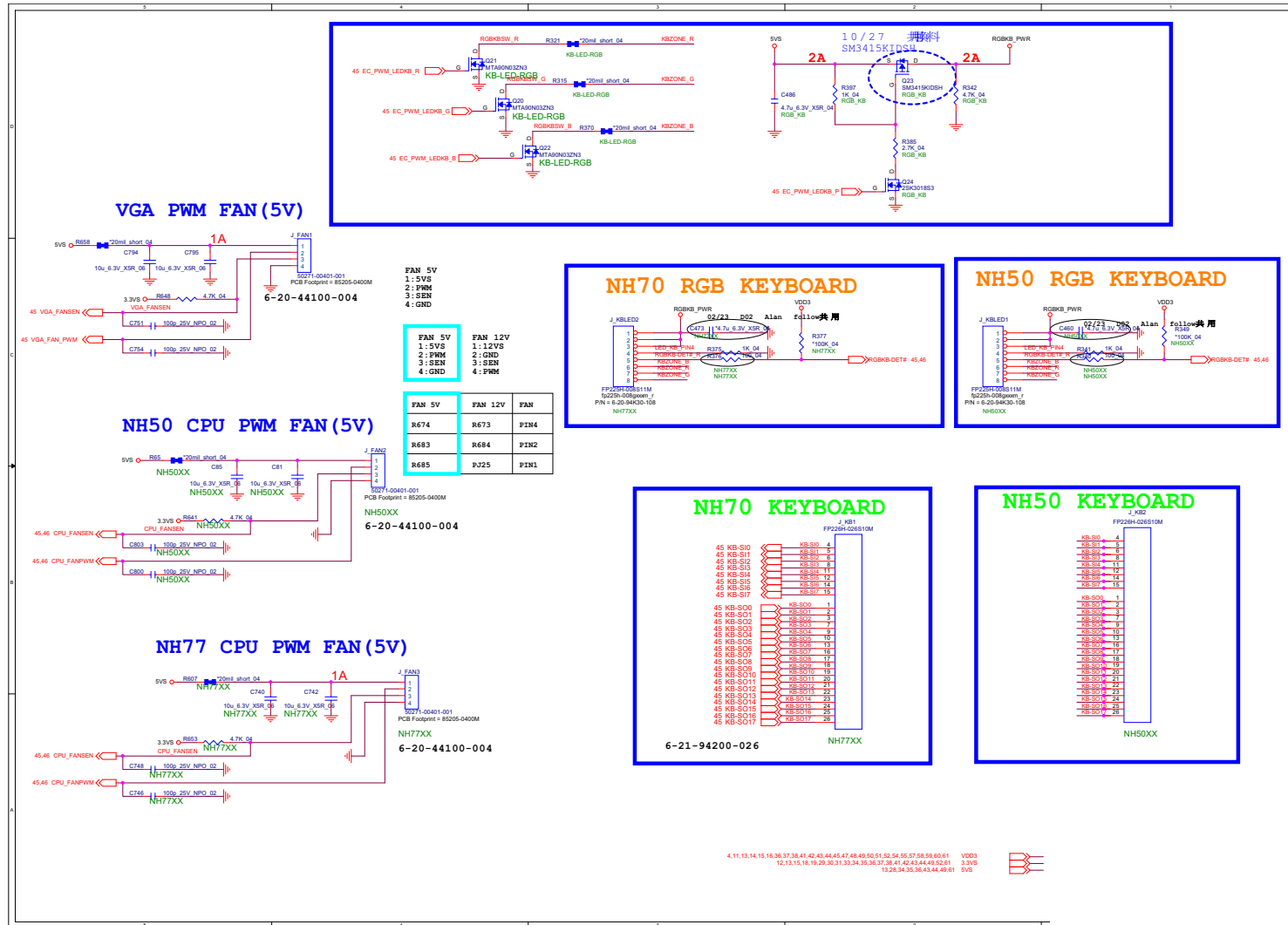

B.Schematic Diagrams

Sheet 46 of 70
RGB KB, Fan

Schematic Diagrams

3V, 5V, 3VS, 5VS

B.Schematic Diagrams

Sheet 49 of 70
3V, 5V, 3VS, 5VS

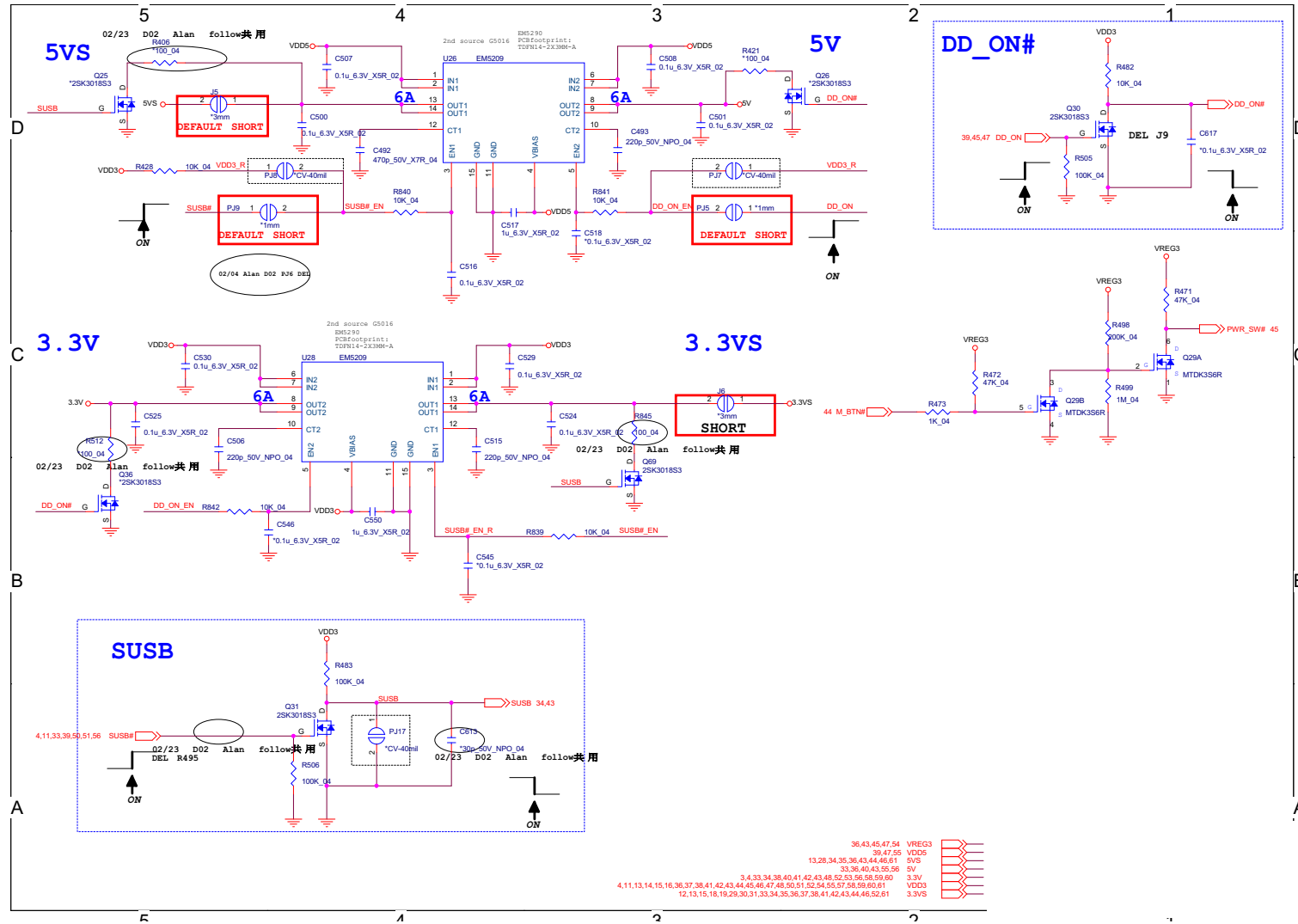

VCCST, VCCSTG, 1.8VS

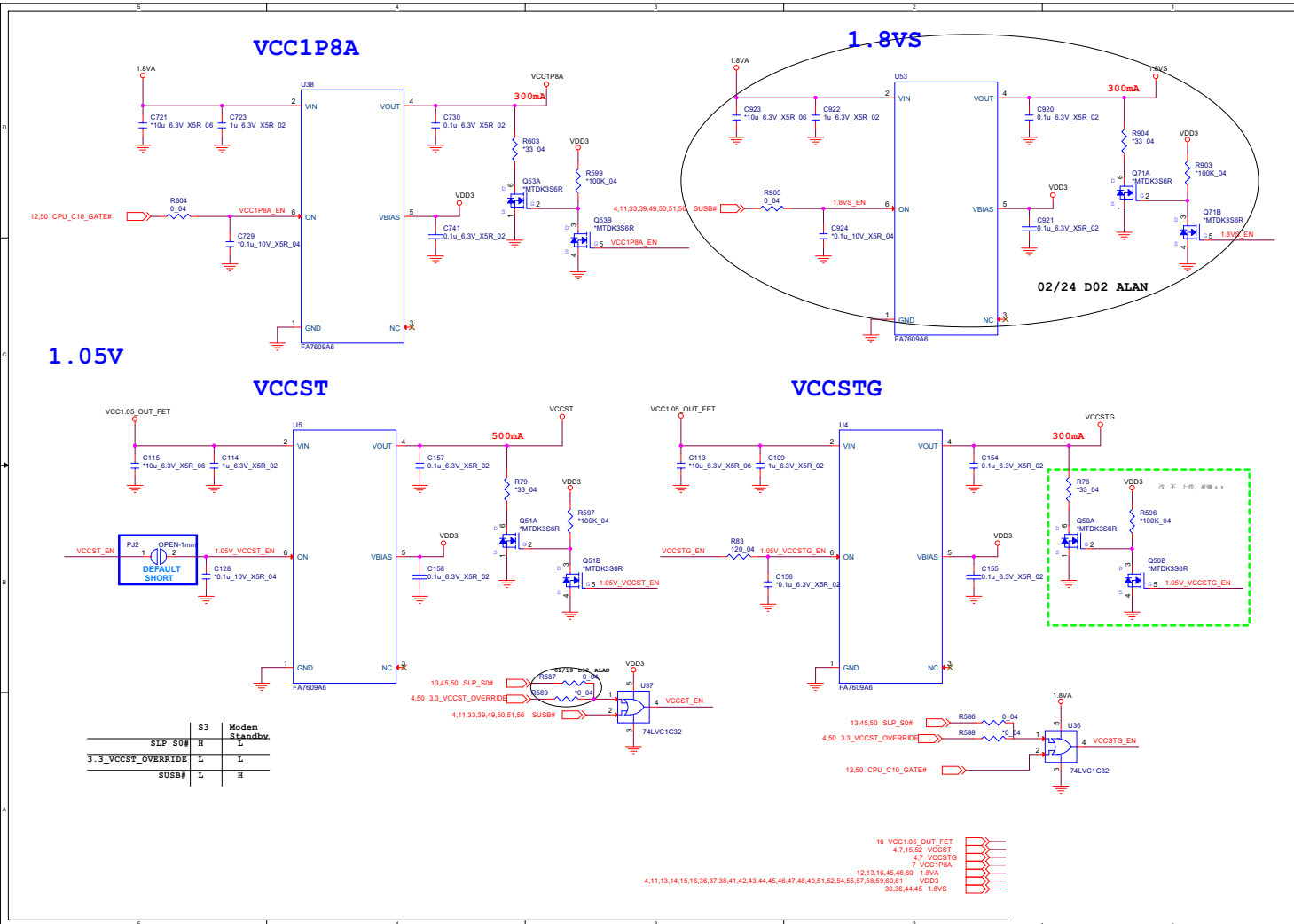

Sheet 50 of 70
VCCST, VCCSTG,
1.8VS

VNN / V1.05

Sheet 51 of 70
VNN / V1.05

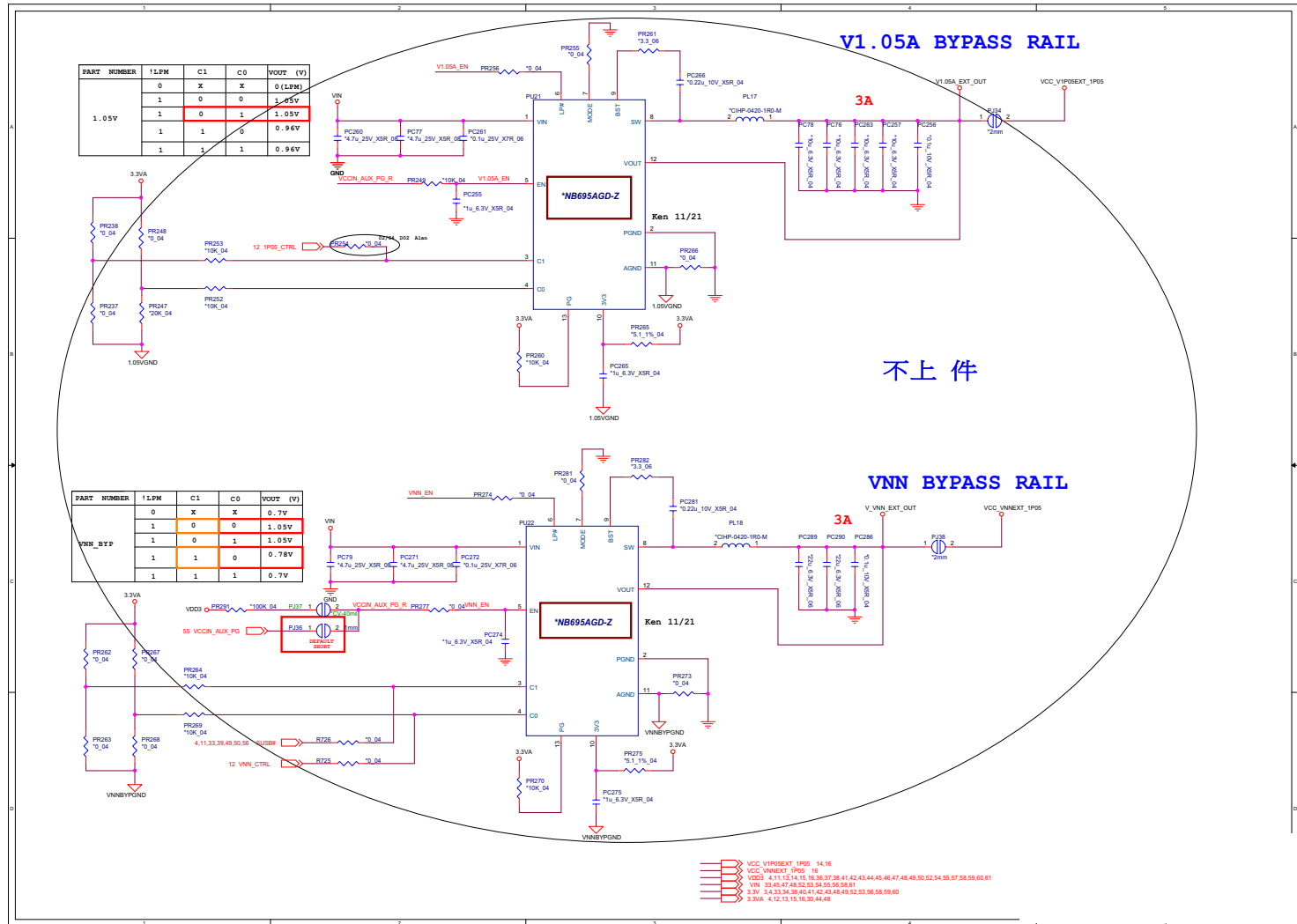

VCCIN Output

Sheet 53 of 70
VCCIN Output

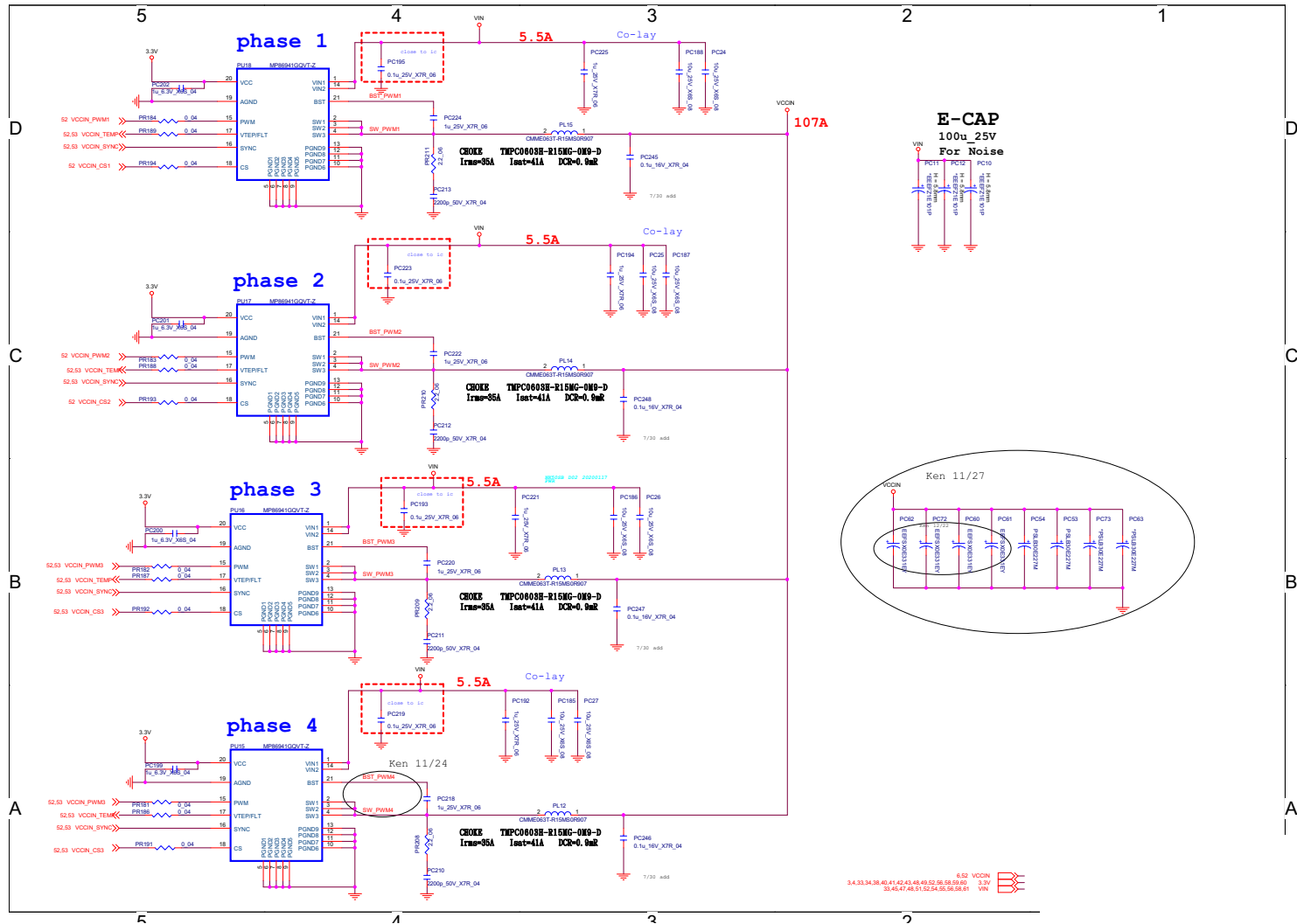

6.52 VCCIN
3.4, 3.3, 3.4, 3.8, 4.0, 4.1, 4.2, 4.3, 4.8, 4.9, 5.2, 5.6, 5.9, 6.0
3.3V
52, 46, 47, 48, 51, 52, 54, 55, 56, 58

AC_In, Charger

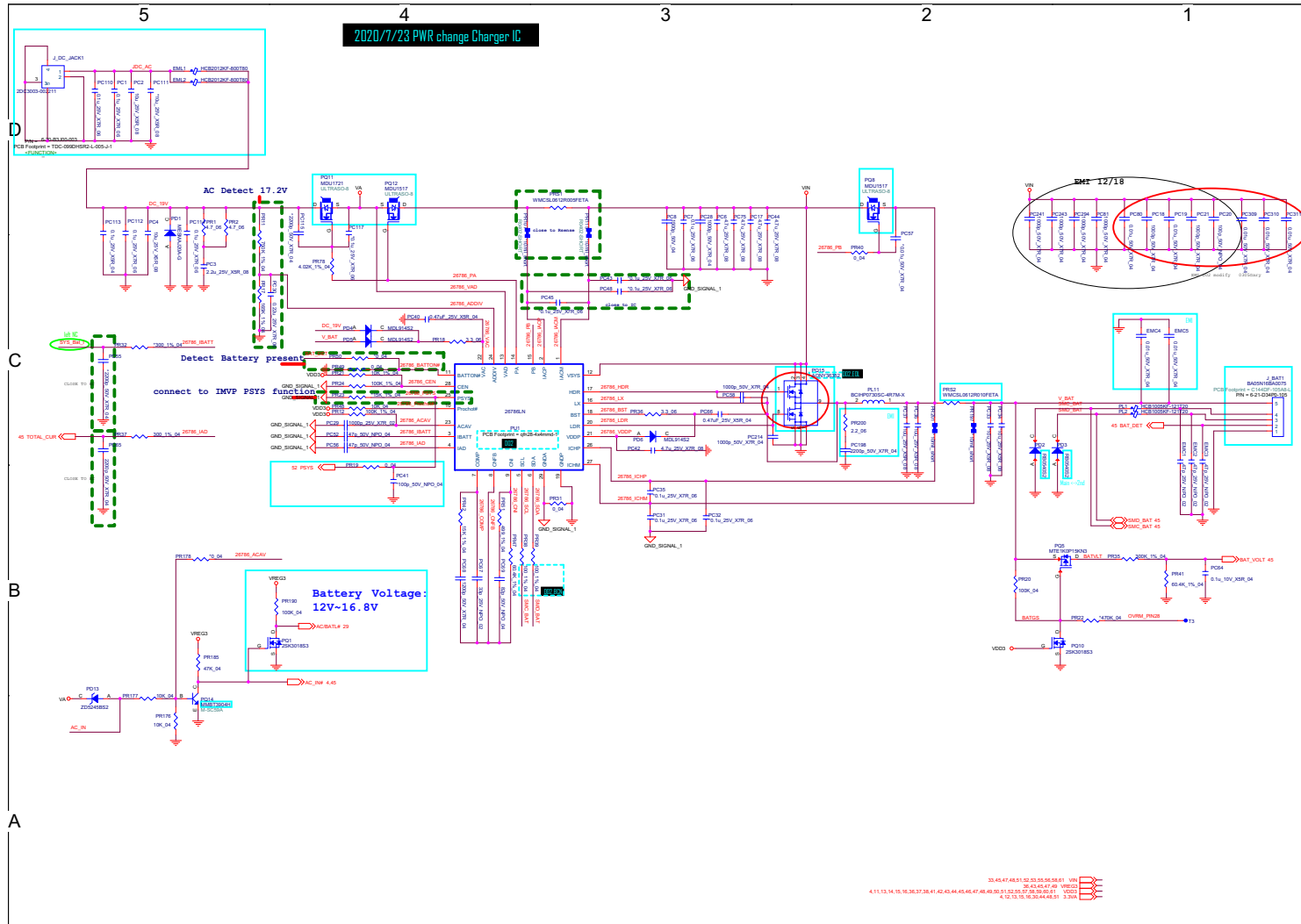

Sheet 54 of 70
AC_In, Charger

VCCIN AUX

Sheet 55 of 70
VCCIN AUX

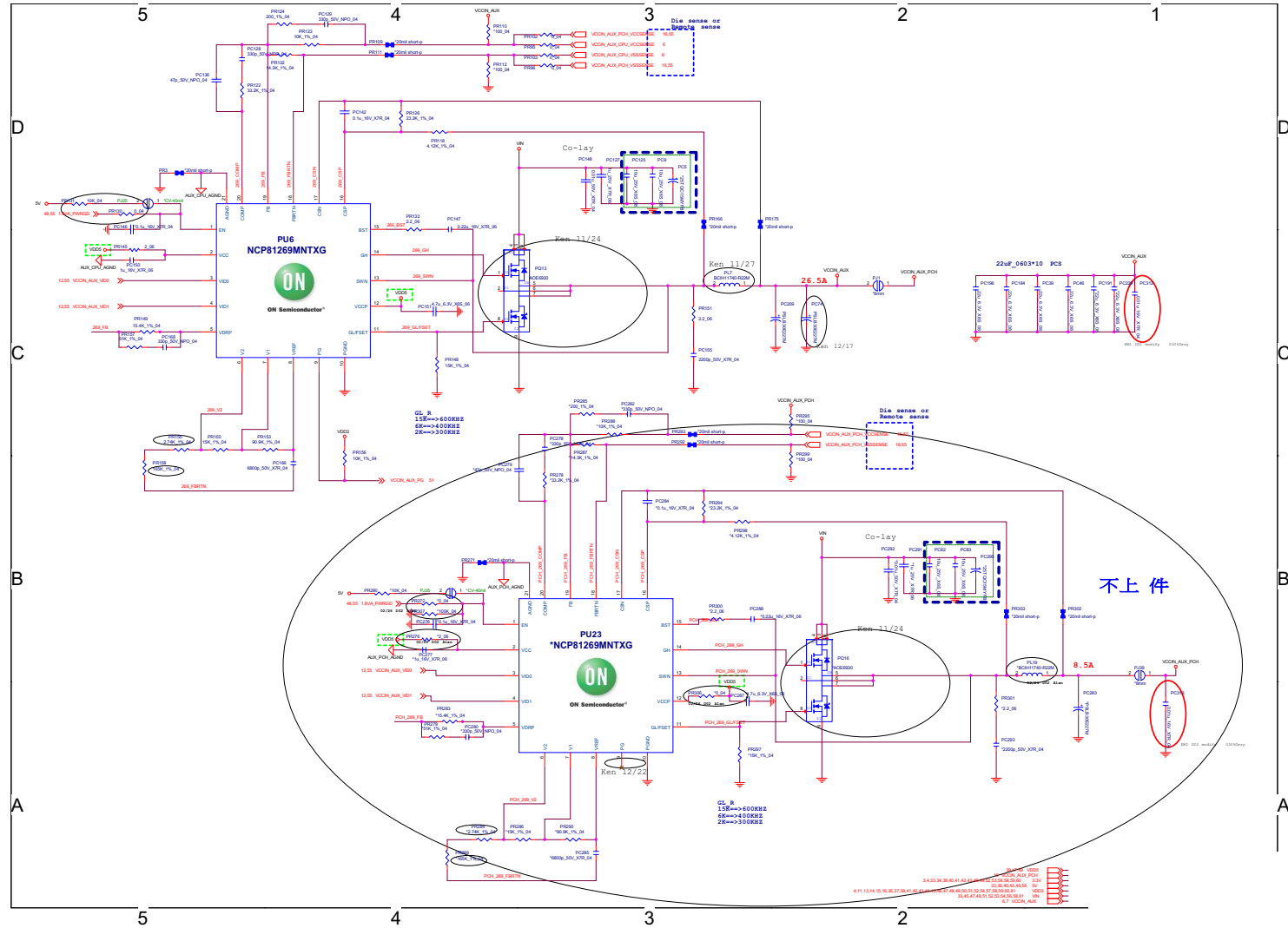

NVVDD2

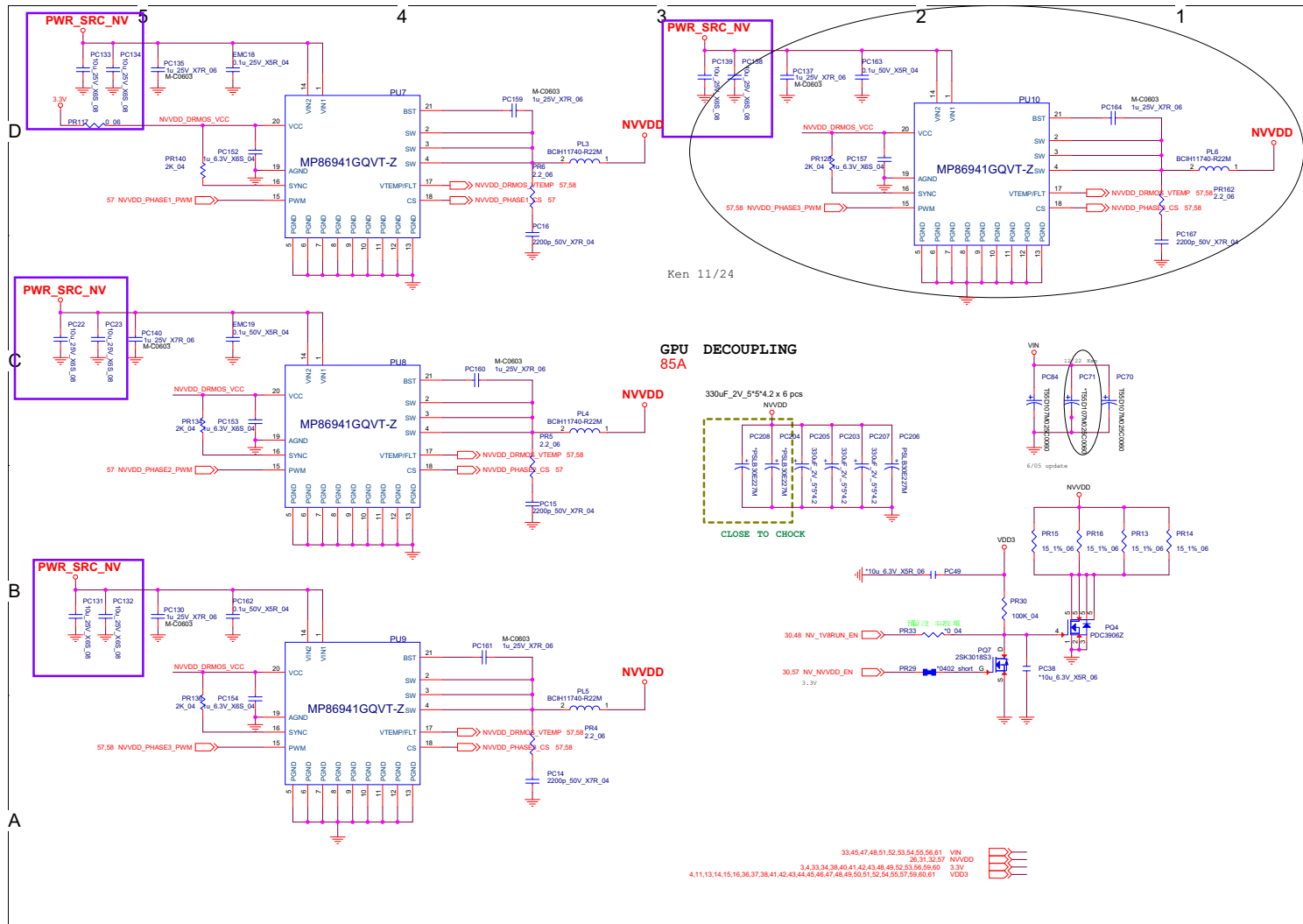

Sheet 58 of 70
NVVDD2

B.Schematic Diagrams

PEX_VDD

Sheet 59 of 70
PEX_VDD

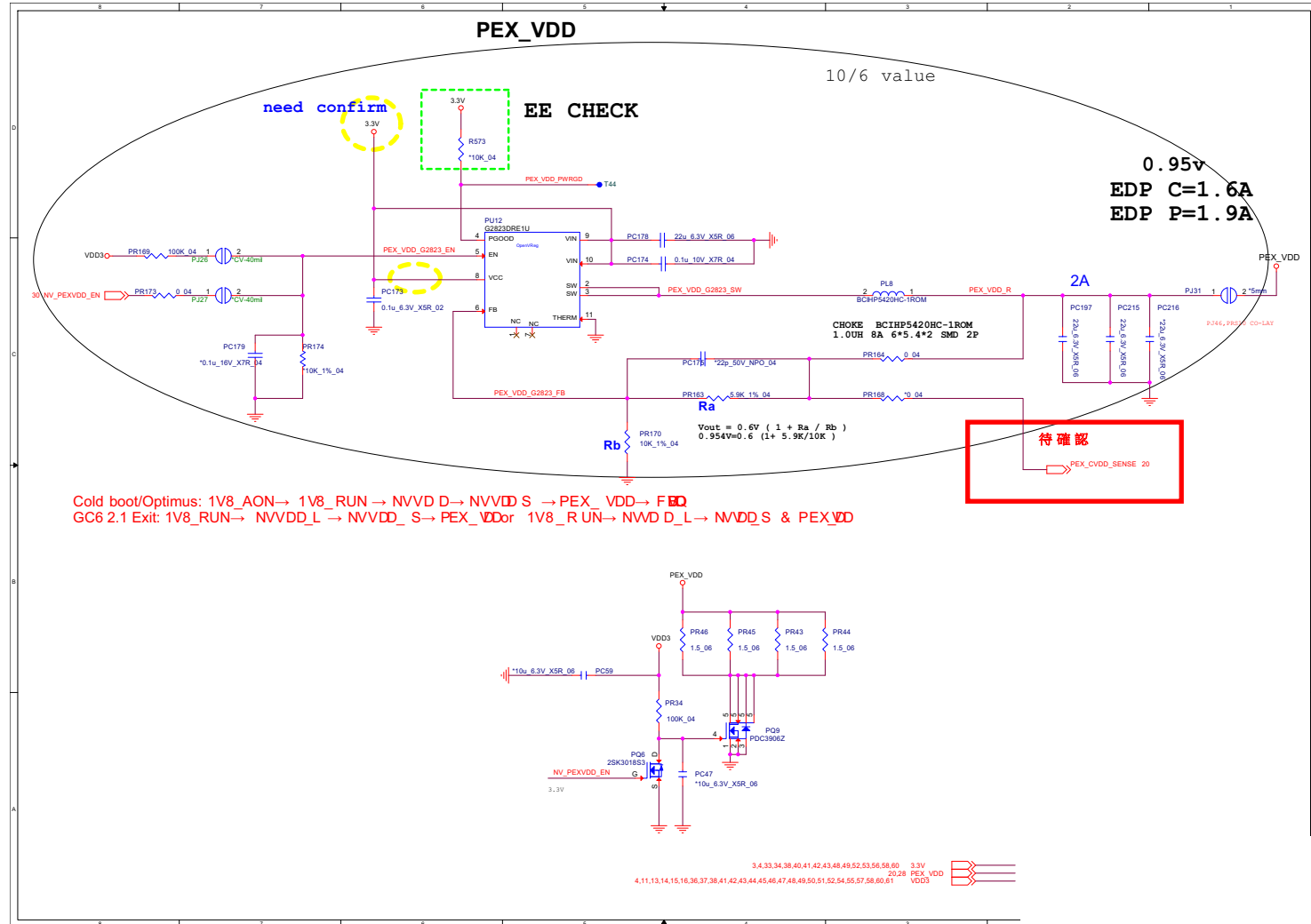

FBVDDQ

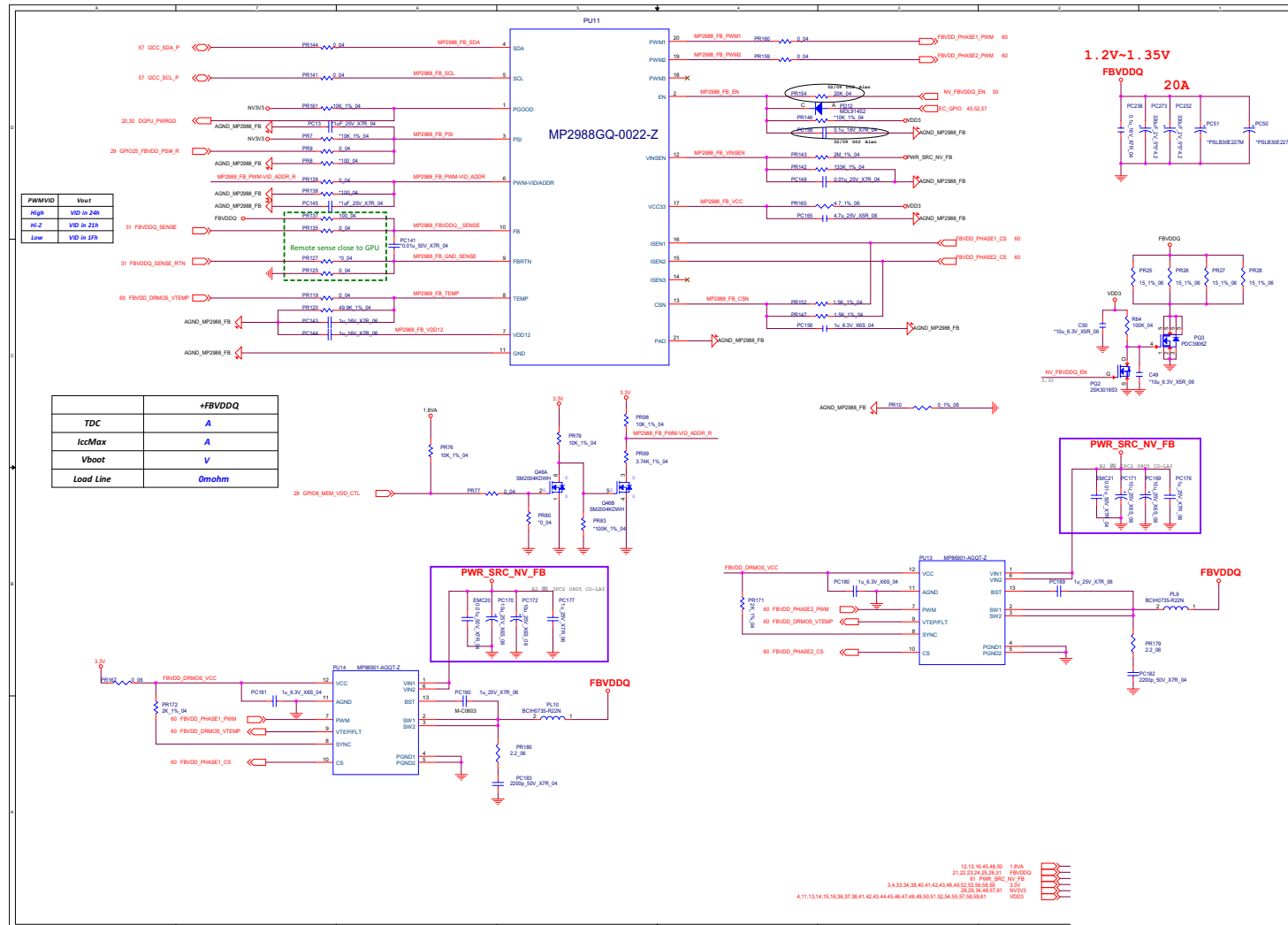

Sheet 60 of 70
FBVDDQ

B.Schematic Diagrams

Click Board

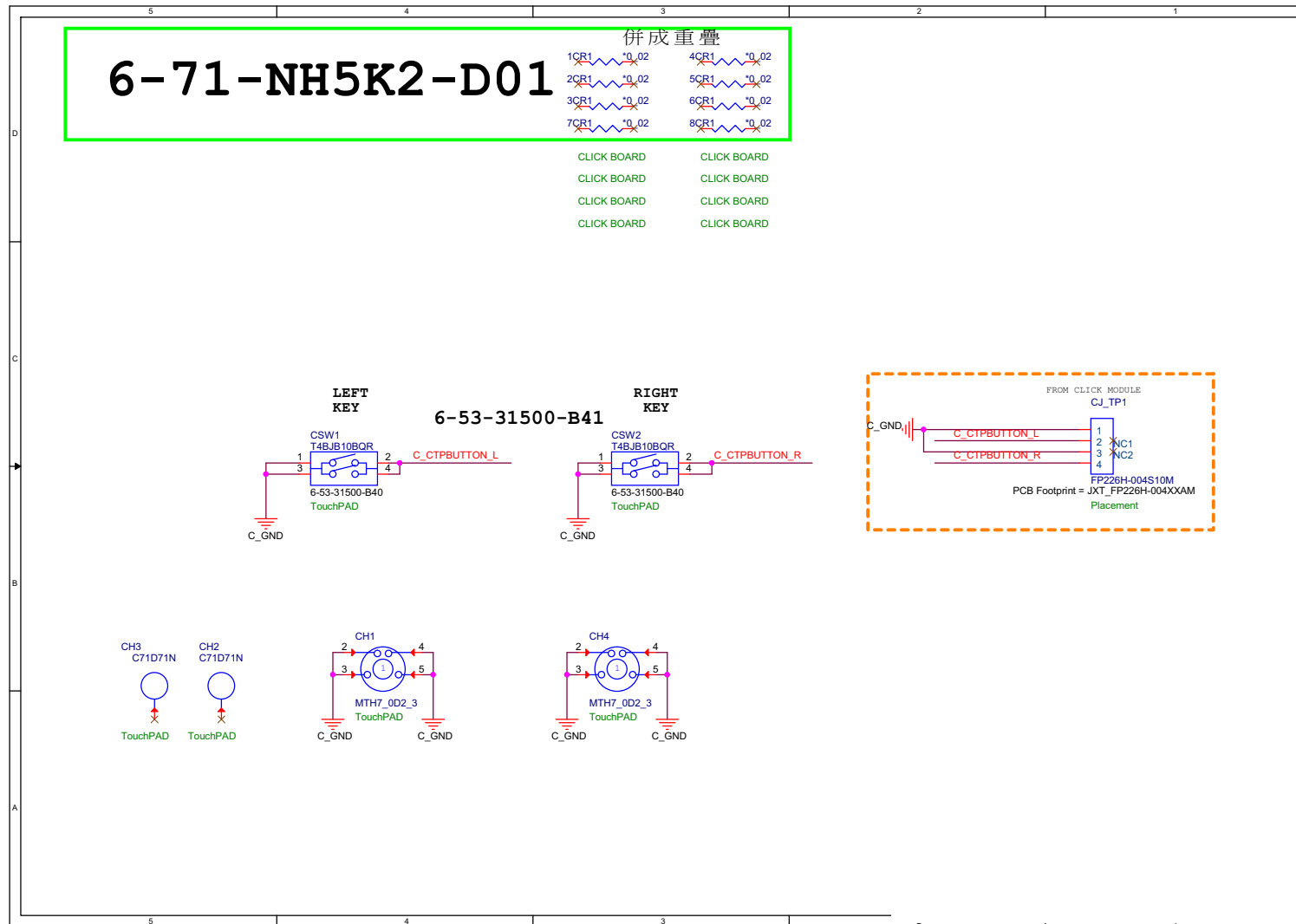

Sheet 62 of 70
Click Board

B.Schematic Diagrams

LED Board

Sheet 63 of 70
LED Board

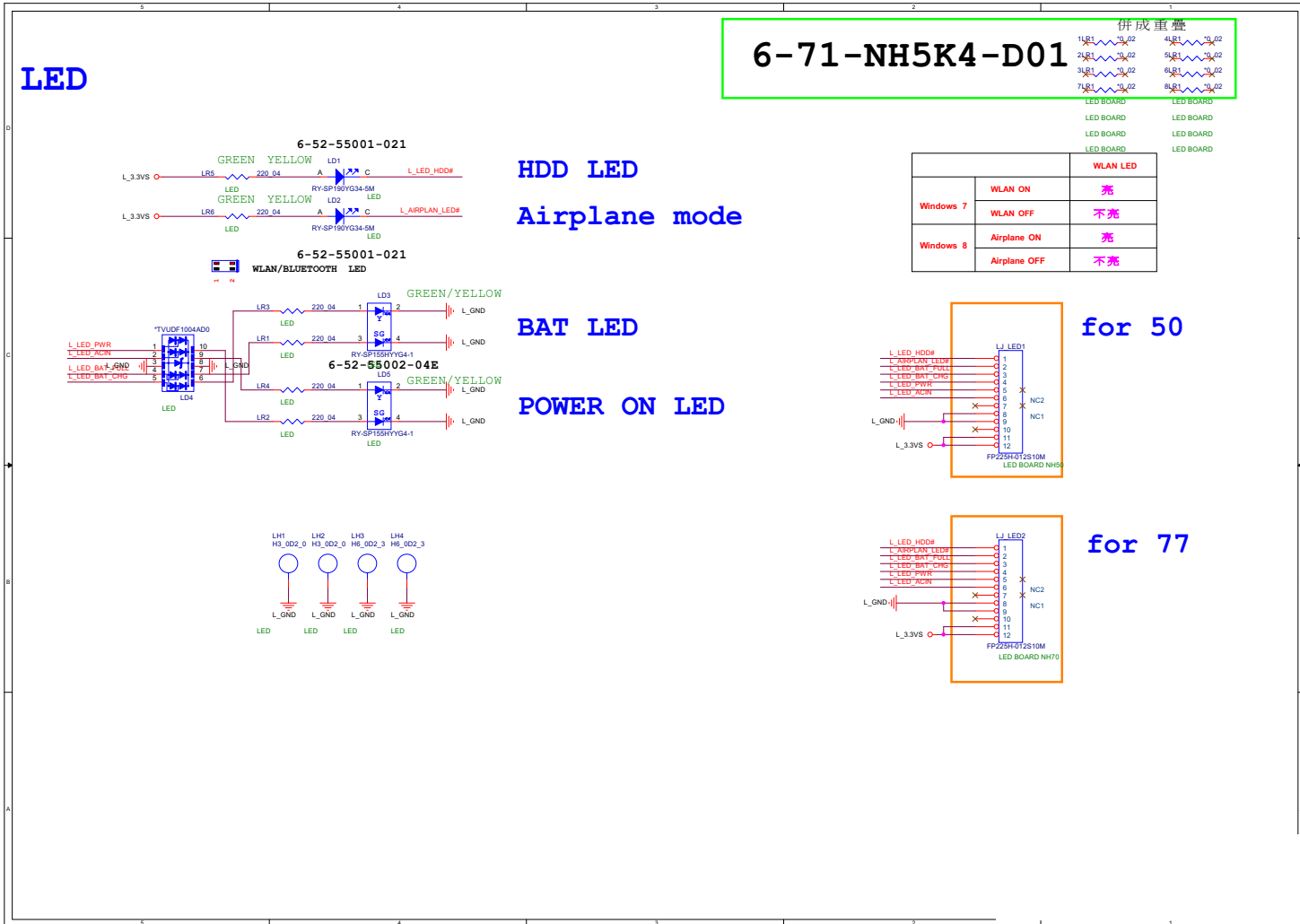

NH77 PW Board

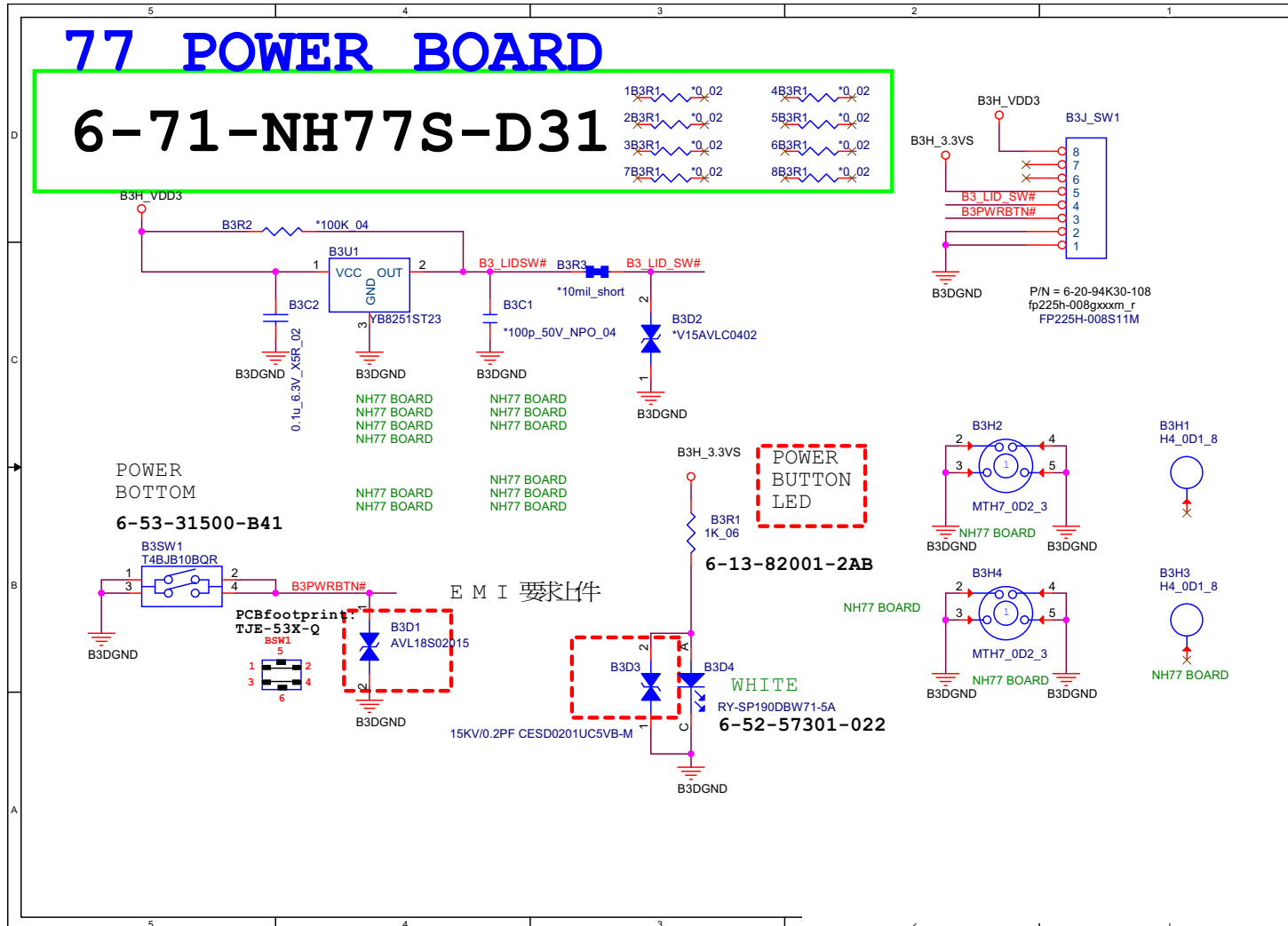

Sheet 66 of 70
NH77 PW Board

NH50 PW Board

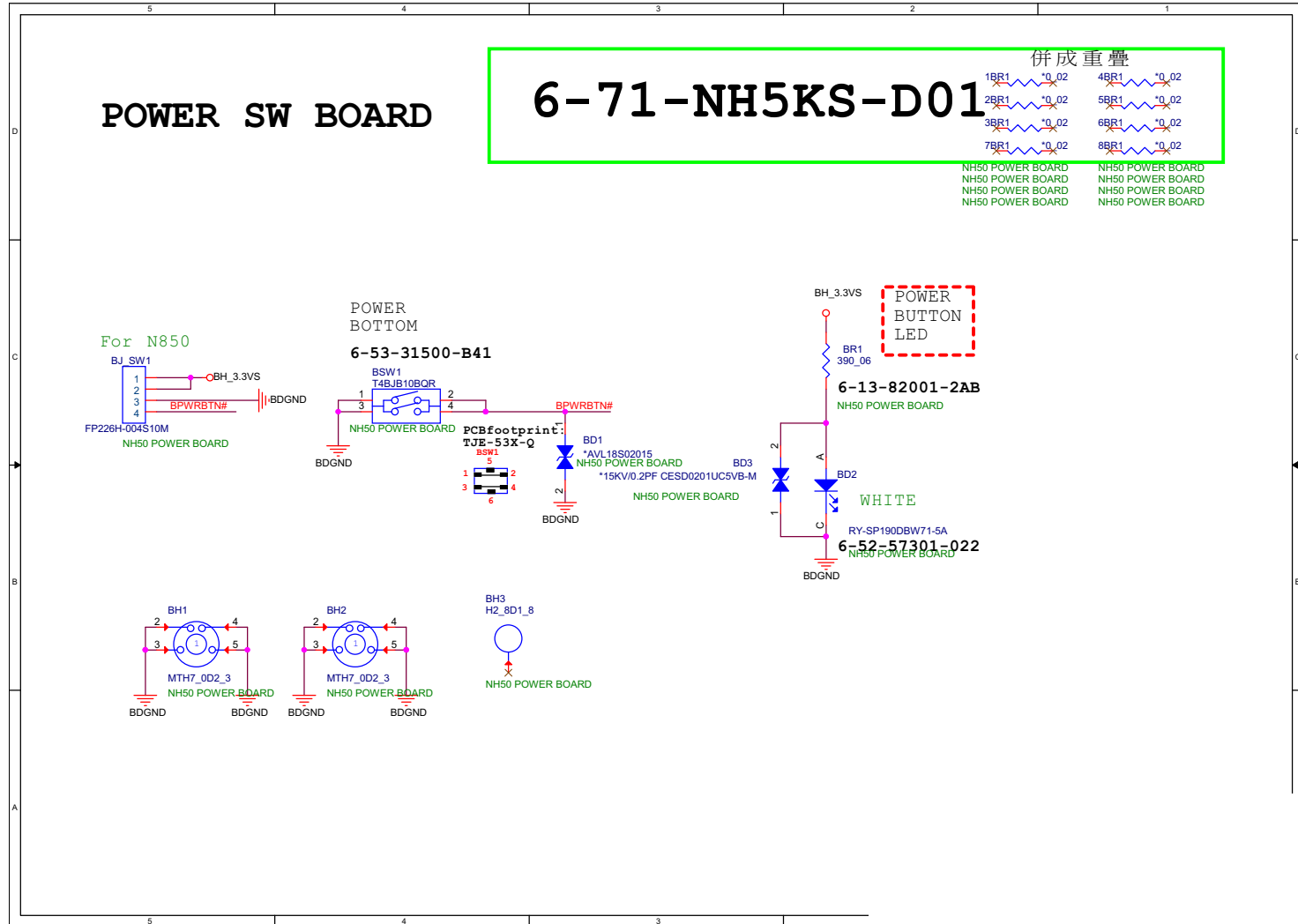

Sheet 67 of 70
NH50 PW Board

B.Schematic Diagrams

NH55 PW Board

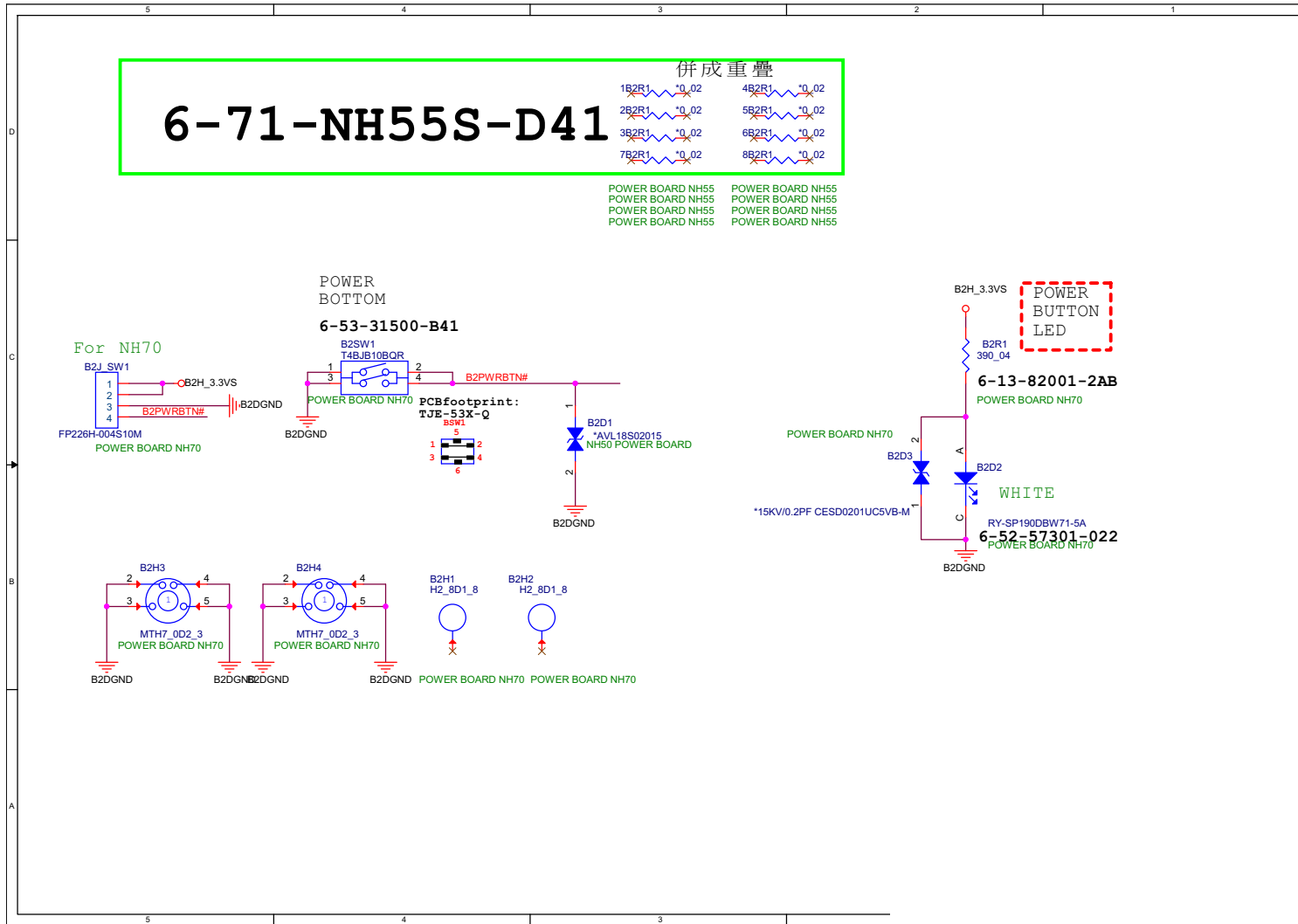

Sheet 68 of 70
NH55 PW Board

Power Sequence

Sheet 69 of 70
Power Sequence

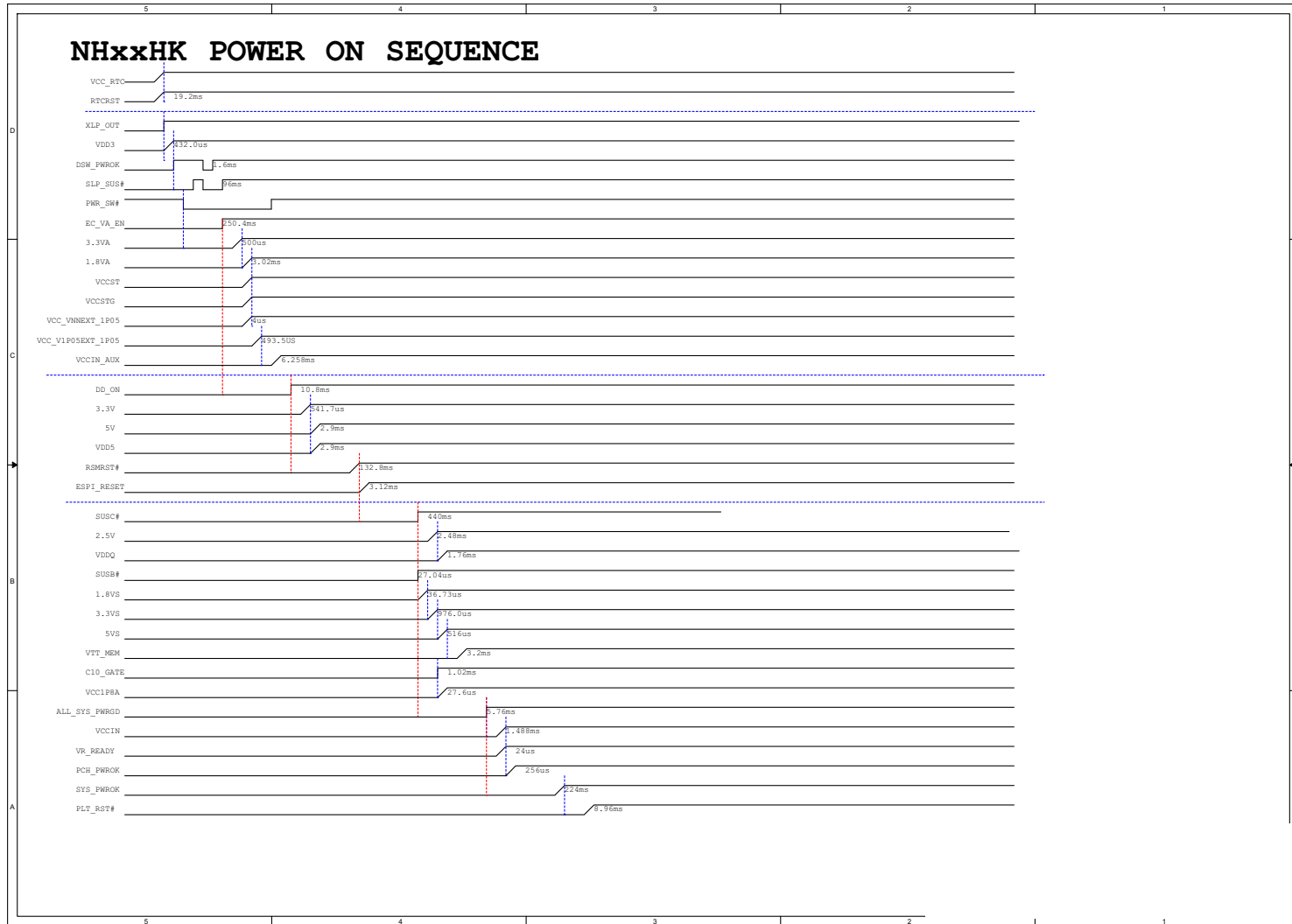

Power Map

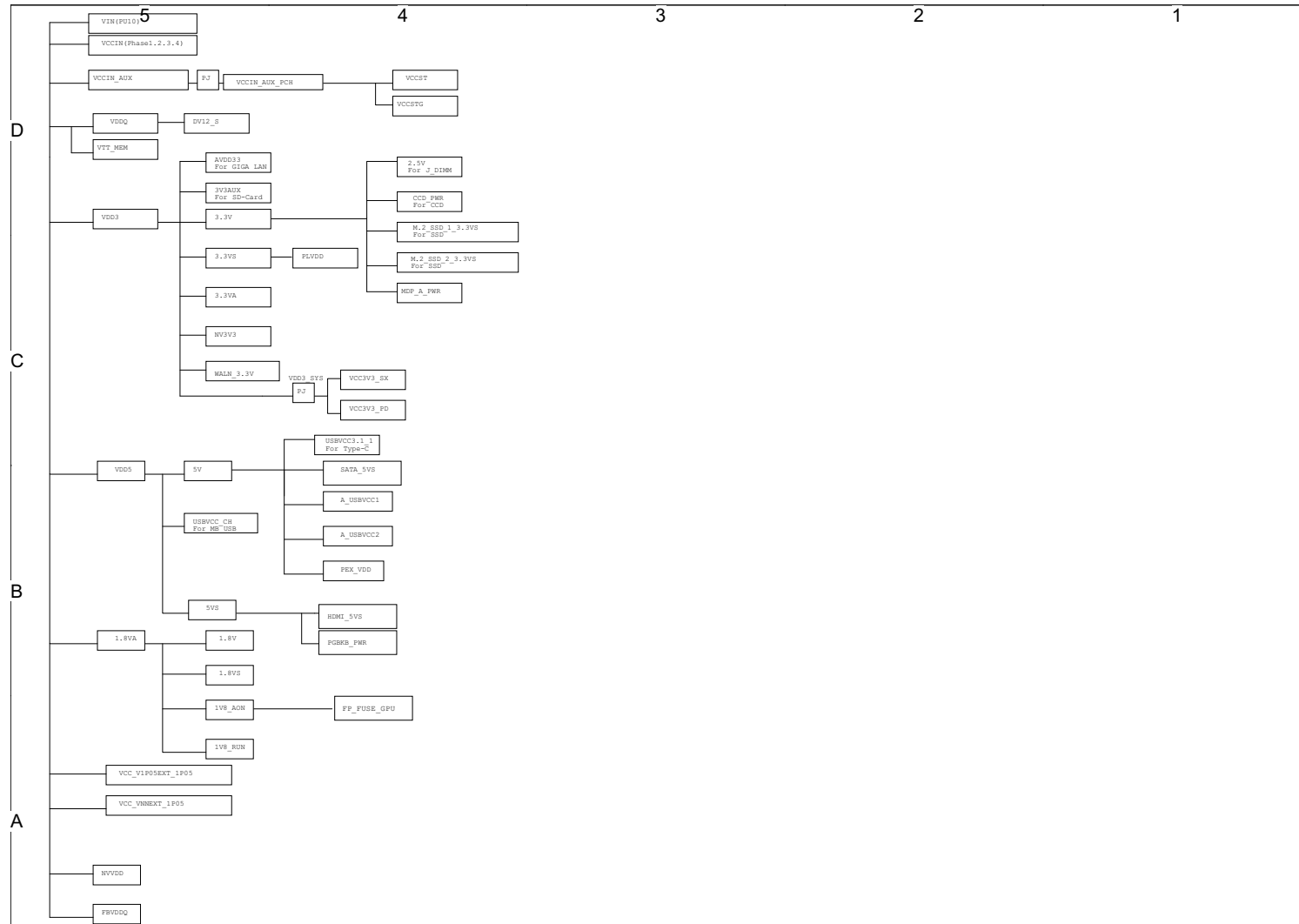

Sheet 70 of 70
Power Map

Schematic Diagrams